

Weighing Indicator for Rail Mount (TS35)

Type DAD 143.x

Communication via 'Ethernet Based Ports' & Service Port RS 232

TECHNICAL MANUAL



Firmware 143.181.v.1.04 or higher
Hardware Version 143.105.v.1
Document No. E 225 Rev 1.2.0 EN

Hauch & Bach ApS
Femstykket 6
DK-3540 Lyngø
Denmark
www.haubac.com

Table of Content

0.	Safety Instructions	6
1.	Declaration of Conformity.....	7
2.	Introduction and Specifications	8
3.	Hardware, Wiring and Communication LED's	9
3.1.	Housing & Terminals	9
3.2.	Terminals Load Cell Connection	9
3.3.	Load Cell Connection	9
3.4.	Terminals Power Supply.....	10
3.5.	Terminals Service Port RS 232	10
3.6.	Ethernet Based Ports.....	10
3.7.	LED Indicators – Terminal 27	11
3.8.	Seal Switch	11
3.9.	Logic Inputs & Outputs.....	12
3.10.	Analog Outputs	12
4.	Communications and Getting started	13
4.1.	Service Port	13
4.2.	Command Language.....	13
4.3.	Baud Rate	13
4.4.	Getting Started via service port RS 232	13
4.5.	Getting Started via Ethernet based Port, e.g. Modbus TCP	14
5.	Menu Structure For Keyboard Setup / Inspection.....	16
6.	Setup Via Front Panel Keyboard	17
6.1.	Keyboard Buttons	17
6.2.	Use of Keyboard Buttons	17
6.3.	Menu 1 – System Zero	18
6.4.	Menu 2 – System Span	19
6.5.	Menu 3 – Display	20
6.6.	Menu 4 – Filter & Motion Detection.....	21
6.7.	Menu 5 – Analog Output.....	22
6.8.	Menu 6 – Logic Inputs.....	23
6.9.	Menu 7 – Logic Outputs.....	24
6.10.	Menu 8 – Data Communication	25
6.11.	Factory Default via Front Panel	27
6.12.	Error Codes - shown in the Front Panel Display	27
7.	Examples of calibration	28
7.1.	Example 1 – Calibration procedure using weights	28
7.2.	Example 2 – Calibration procedure using load cell's mV/V sensitivity	30
8.	Setup via PC / PLC - Command Overview -	32
8.1.	Special Commands of DAD143.x – Overview	34
8.1.1.	AT Auto Transmit (only for RS 232 connection)	34
8.1.2.	AT Auto Transmit (for PLC connection).....	34
8.1.3.	LE Last Error (cmd only for RS 232 connection)	35

Setup via PC / PLC - Command Descriptions.....	36
8.2. System Diagnosis Commands – ID, IH, IV, IS, SR, RS	36
8.2.1. ID Get Device Identity	36
8.2.2. IV Get Firmware Version	36
8.2.3. IS Get Device Status	36
8.2.4. SR Reset DAD143.x Firmware.....	36
8.2.5. RS Read Serial Number.....	37
8.3. Calibration Commands – CE, CM'n', CI, MR, DS, DP, CZ, CG, ZT, FD, ZR, ZI, AZ, AG, CS, SU, RU, FT.....	37
8.3.1. CE Read TAC* Counter / Open Calibration Sequence.....	37
8.3.2. CM'n' Set Maximum Output Value	37
8.3.3. CI Set Minimum Output Value	38
8.3.4. MR Set Multi-range / Multi-interval	38
8.3.5. DS Set Display Step Size.....	38
8.3.6. DP Set Decimal Point Position	39
8.3.7. CZ Set Calibration Zero Point	39
8.3.8. CG Set Calibration Gain (Span)	39
8.3.9. CV Calibrate Value.....	39
8.3.10. AV Show Actual Internal mV/V Value.....	39
8.3.11. ZT Zero Tracking.....	39
8.3.12. FD Reset to Factory Default Settings	40
8.3.13. ZR Zero Range.....	40
8.3.14. ZI Initial Zero ON / OFF	40
8.3.15. TM Tare mode.....	40
8.3.16. TN Set / Clear Non-Volatile Tare.....	41
8.3.17. ZN Set / Clear Non-Volatile Zero.....	41
8.3.18. ZM Zero Mode.....	41
8.3.19. AZ Absolute zero point calibration (eCal)	41
8.3.20. AG Absolute gain calibration (eCal)	41
8.3.21. CS Save the Calibration Data	42
8.3.22. SU Save User Setup in EEPROM.....	42
8.3.23. RU Restore User Setup to DAD143.x	42
8.3.24. FT Firmware Type	42
8.4. Motion Detection Commands – NR, NT.....	43
8.4.1. NR Set 'No-motion' Range	43
8.4.2. NT Set 'No-motion' Time Period.....	43
8.5. Filter Setting Commands – FM, FL, PF, UR.....	43
8.5.1. FM Filter Mode	43
8.5.2. FL Filter Settings	44
8.5.3. PF Pre-filter	46
8.5.4. UR Update Rate and Averaging	46
8.6. Taring and Zeroing Commands – SZ, RZ, ZN, ST, RT, SP, TN, RW, TI	46
8.6.1. SZ Set System Zero	46
8.6.2. RZ Reset Zero.....	46
8.6.3. ST Set Tare.....	47
8.6.4. RT Reset Tare.....	47
8.6.5. SP Set Preset Tare	47
8.6.6. TW Window for Automatic Taring.....	47
8.6.7. TI Averaging Time for Automatic Taring.....	47
8.7. Output Commands – GG, GN, ON, GT, GS, GW, GA, GH, GM, RM, GO, GV	48
8.7.1. GG Get Gross Value	48
8.7.2. GN Get Net Value	48
8.7.3. GT Get Tare Value	48
8.7.4. GS Get ADC Sample Value	48
8.7.5. GW Get Data String "Net, Gross and Status"	48
8.7.6. OF Output Format for Data String GW	49
8.7.7. GA Get Triggered Average Value	49
8.7.8. GH Get Hold Value.....	49
8.7.9. TH Trigger Hold Value.....	50
8.7.10. GM Get Peak Value	50
8.7.11. RM Reset of Peak Value.....	50
8.7.12. GO Get Peak To Peak Value	50
8.7.13. GV Get Valley Value	50
8.8. Auto-Transmit Commands – SG, SN, SW, SA, SH, SM, SO, SV	50
8.8.1. SG Send Gross Value continuously	50
8.8.2. SN Send Net Value continuously	50
8.8.3. SW Send Data String "Net, Gross and Status" continuously.....	51

8.8.4.	SA	Send Triggered Average Value automatically.....	51
8.8.5.	SH	Send Hold Value continuously.....	51
8.8.6.	SM	Send Peak Value continuously	51
8.8.7.	SO	Send Peak To Peak Value continuously	51
8.8.8.	SV	Send Valley Value continuously	51
8.9.	Logic Input Functions & Status – AI'n', IN		51
8.9.1.	AI	Assign input 'n'	51
8.9.2.	IN	Read status of the logic inputs	52
8.10.	Logic Output Commands - IO, OM, S'n', H'n', P'n', A'n', HT		52
8.10.1.	IO	Read / Modify the Status of the logic Outputs	52
8.10.2.	OM	Control of the logic outputs by the host application	52
8.10.3.	A'n'	Assign action for setpoint 'n'	53
8.10.4.	S'n'	Setpoint Value	53
8.10.5.	H'n'	Setpoint Hysteresis and Switching Action	53
8.10.6.	P'n'	Polarity of Setpoint	54
8.10.7.	HT	Hold time for all Setpoints.....	54
8.11.	Communication Setup Commands – AD, BR, DX, OP, CL, TD.....		55
8.11.1.	AD	Device Address	55
8.11.2.	BR	Baud Rate	55
8.11.3.	DX	Operation Mode Half-/Full-Duplex	55
8.11.4.	OP	Open Device	55
8.11.5.	CL	Close Devices.....	55
8.12.	Analog Output – AA, AH, AL, AM, AR (only DAD 143.1)		55
8.12.1.	AA	Analog Output Base	56
8.12.2.	AH	Set Analog High Level.....	56
8.12.3.	AL	Set Analog Low Level	56
8.12.4.	AM	Set Analog Output Mode.....	56
8.12.5.	AR	Set Analog Reference Value	56
8.13.	Save Calibration and Setup – CS, WP, SS, AS, GI, PI		57
8.13.1.	CS	Save the Calibration Data	57
8.13.2.	WP	Save the Setup Parameters	57
8.13.3.	SS	Save Setpoint Parameters.....	57
8.13.4.	AS	Save Analog Output Parameters (only DAD 143.1).....	57
8.13.5.	GI	Get an Image File from the EEPROM	57
8.13.6.	PI	Download an Image File to the EEPROM.....	58
8.14.	Trigger Commands – SD, MT, GA, TE, TR, TL, SA		58
8.14.1.	SD	Start Delay Time.....	58
8.14.2.	MT	Measuring Time	58
8.14.3.	GA	Get Triggered Average Value	58
8.14.4.	TE	Trigger Edge	58
8.14.5.	TR	Software Trigger	59
8.14.6.	TL	Trigger Level	59
8.14.7.	SA	Send Triggered Average Value automatically	59
9.	Legal For Trade Applications		59
9.1.	Access to metrological data and weighing range adjustment		60
9.2.	Protection of the metrological data and the scale calibration		60
10.	Calibration and Calibration Sequence.....		61
11.	Firmware Update Program.....		62
11.1.	FU	Firmware Update	62
11.2.	FD	Reset to Factory Default Settings	62
11.3.	Import / Export of the Device Settings		63

Part 2 – Modbus TCP Commands	64
12. Service Commands – Overview Modbus TCP	64
12.1. General System Commands – PS, SR and WP	64
12.1.1. PS Protocol Select	64
12.1.2. SR Software Reset.....	64
12.1.3. WP Write Parameters.....	64
12.2. Ethernet Setup Commands – NA, NM, NG, AP and MA	65
12.2.1. NA Network Address.....	65
12.2.2. NM Network Mask.....	65
12.2.3. NG Network Gateway.....	65
12.2.4. AP Address assign Protocol.....	65
12.2.5. MA MAC Addresses.....	66
13. Data Transfer - Modbus TCP	66
13.1. Data read from the DAD 143.x by the PLC	66
13.1.1. Data package read from the DAD 143.x.....	66
13.1.2. CmdStatus	66
13.1.3. CmdRdData	67
13.1.4. Data1.....	67
13.1.5. Data2.....	67
13.1.6. Qualifier.....	67
13.1.7. IO Status.....	67
13.1.8. Data Type1.....	67
13.1.9. Data Type2.....	67
13.2. Data written from the PLC to the DAD 143.x	67
13.2.1. Data package written to the DAD 143.x	67
13.2.2. CmdWrData	67
13.2.3. Index	68
13.2.4. Subindex	68
13.2.5. RW	68
13.2.6. SendCmd	68
13.2.7. ShortCmd.....	68
13.2.8. Select1	68
13.2.9. Select2	68
14. Appendix A – Command list ‘MODBUS TCP’ for the DAD 143.x	69
15. Appendix B - Change network settings AP, NA, NM and NG with Modbus TCP Viewer	76

RIGHTS AND LIABILITIES

All rights reserved.

No part of this publication may be reproduced, stored in a retrieval system, or transmitted in any form or by any means, mechanical, photocopying, recording, or otherwise, without the prior written permission of Hauch & Bach ApS.

No patent liability is assumed with respect to the use of the information contained herein. While every precaution has been taken in the preparation of this book, Hauch & Bach assumes no responsibility for errors or omissions. Neither is any liability assumed for damages resulting from the use of the information contained herein.

The information herein is believed to be both accurate and reliable. Hauch & Bach, however, would be obliged to be informed if any errors occur. Hauch & Bach cannot accept any liability for direct or indirect damages resulting from the use of this manual.

Hauch & Bach reserves the right to revise this manual and alter its content without notification at any time.

Neither Hauch & Bach nor its affiliates shall be liable to the purchaser of this product or third parties for damages, losses, costs, or expenses incurred by purchaser or third parties as a result of: accident, misuse, or abuse of this product or unauthorized modifications, repairs, or alterations to this product, or failure to strictly comply with Hauch & Bach operating and maintenance instructions.

Hauch & Bach shall not be liable against any damages or problems arising from the use of any options or any consumable products other than those designated as Original Hauch & Bach Products.

NOTICE: The contents of this manual are subject to change without notice.

Copyright © 2012-2020 by Hauch & Bach ApS, DK-3540 Lyngby, Femstykke 6, Denmark

0. Safety Instructions



CAUTION READ this manual BEFORE operating or servicing this equipment. FOLLOW these instructions carefully. SAVE this manual for future reference. DO NOT allow untrained personnel to operate, clean, inspect, maintain, service, or tamper with this equipment. ALWAYS DISCONNECT this equipment from the power source before cleaning or performing maintenance. CALL Hauch & Bach ApS for parts, information, and service.



WARNING ONLY PERMIT QUALIFIED PERSONNEL TO SERVICE THIS EQUIPMENT. EXERCISE CARE WHEN MAKING CHECKS, TESTS AND ADJUSTMENTS THAT MUST BE MADE WITH POWER ON. FAILING TO OBSERVE THESE PRECAUTIONS CAN RESULT IN BODILY HARM.



WARNING FOR CONTINUED PROTECTION AGAINST SHOCK HAZARD CONNECT TO PROPERLY GROUNDED OUTLET ONLY. DO NOT REMOVE THE GROUND PRONG.



WARNING DISCONNECT ALL POWER TO THIS UNIT BEFORE REMOVING THE FUSE OR SERVICING.



WARNING BEFORE CONNECTING/DISCONNECTING ANY INTERNAL ELECTRONIC COMPONENTS OR INTERCONNECTING WIRING BETWEEN ELECTRONIC EQUIPMENT ALWAYS REMOVE POWER AND WAIT AT LEAST THIRTY (30) SECONDS BEFORE ANY CONNECTIONS OR DISCONNECTIONS ARE MADE. FAILURE TO OBSERVE THESE PRECAUTIONS COULD RESULT IN DAMAGE TO OR DESTRUCTION OF THE EQUIPMENT OR BODILY HARM.



CAUTION OBSERVE PRECAUTIONS FOR HANDLING ELECTROSTATIC SENSITIVE DEVICES.

1. Declaration of Conformity

EG-Konformitätserklärung EC-Declaration of Conformity

Monat/Jahr: *month/year*: 11/2020
Hersteller: *Manufacturer*: Hauch & Bach ApS
Anschrift: *Address*: Femstykke 6
DK-3540 Lyngø
Dänemark / Denmark
Produktbezeichnung: *Product name*: DAD 143.x

Das bezeichnete Produkt stimmt mit folgenden Vorschriften der Europäischen Richtlinien überein:
This product confirms with the following regulations of the Directives of the European Community:

Richtlinie 2014/30/EU des Europäischen Parlaments und des Rates vom 26. Februar 2014 zur Angleichung der Rechtsvorschriften der Mitgliedstaaten über die elektromagnetische Verträglichkeit und zur Aufhebung der Richtlinie 2004/108/EG.

Directive 2014/30/EU of the European Parliament and of the Council of 26th February 2014 on the approximation of the laws of the Member States relating to electromagnetic compatibility and repealing Directive 2004/108/EC.

Diese Erklärung bescheinigt die Übereinstimmung mit den genannten Richtlinien, beinhaltet jedoch keine Zusicherung von Eigenschaften.

This declaration certifies the conformity with the listed directives, but it is no promise of characteristics.

Richtlinie 2014/35/EU Niederspannungs-Richtlinie **Directive 2014/35/EU** Low Voltage Directive

Folgende Normen werden zum Nachweis der Übereinstimmung mit den Richtlinien eingehalten:
As a proof of conformity with the directives following standards are fulfilled:

OIML R-76 Nicht-Selbsttätige Waagen – Metrologische und technische Anforderungen (OIML R-76:2006)
Non-automatic weighing systems – Metrological and technical requirements (OIML R-76:2006)
(in Vorbereitung – *pending*)

EN 45501 Metrologische Aspekte nichtselbsttätiger Waagen (EN 45501:2015)
Metrological aspects of non-automatic weighing instruments (EN 45501:2015).
Anhang B.3: Funktionsprüfungen unter Störeinflüssen.
Anhang C: Verfahren für die Prüfung der Störfestigkeit gegen hochfrequente elektromagnetische Felder.



Michael Bach
Managing Director

2. Introduction and Specifications

The **all-in-one** Digital Amplifier DAD 143.x is a universal device for any weighing, filling or dosing operation and for force measurements with strain gage sensors. The DAD143.x is for DIN (TS35) rail mount.

To grant the quality and allow legal weighing, the DAD143.x is OIML R-76 approved (pending).

The DAD 143.x supports a number of industrial Ethernet based protocols for industrial weighing, control and registration, i.e. analog current or voltage output (0/4...20 mA, 0...5V, 0...10V, -5V...+5V and -10V...+10V), Ethernet based ports [ProfiNet, Modbus TCP, Ethernet/IP, EtherCat], RS 232 and logic I/O's for direct control of valves or bars etc.

The device can be controlled either by the front keys, via RS232 port or 2 Ethernet ports. The 2 logic inputs and 3 logic outputs make complex control functions easy. The 3 logic outputs can be controlled external, too.

DAD 143.x Specifications	
Accuracy class	III
Test certificate according OIML R76	EU Type approved for 10000 intervals
AD converter	Delta-Sigma, ± 24 bit
Analog input range	± 15 mV bipolar (± 3 mV/V @ 5 VDC excitation)
Minimum input sensitivity	0.2 μ V/e (legal for trade); 0.05 μ V/d (non legal for trade)
Linearity	< 0.001 % FS
Temperature effect on zero	< ± 4 ppm/ $^{\circ}$ K (typical < ± 2 ppm/ $^{\circ}$ K)
Temperature effect on span	< ± 8 ppm/ $^{\circ}$ K (typical < ± 4 ppm/ $^{\circ}$ K)
Excitation	5 V DC, load cell(s) resistance 50 - 2000 ohms; 6 wire technic
Conversion rate	Max. 600 values/second, selectable in 8 steps
Resolution external	$\pm 600\,000$ counts @ ± 3 mV/V input signal
CALIBRATION & WEIGHING FUNCTIONS	
Calibration	Electronical calibration in mV/V (eCal) or with test weight(s)
Digital low pass filter	FIR Filter 2.5 to 19.7 Hz or IIR Filter 0.25 to 18 Hz - adjustable in 8 steps
Weighing functions	Zero, gros, tare, net, filter, etc.
Application modes	None automatic weighing instrument (NAWI) or triggered measurement
Communication & Setup	
Communication ports	RS232 and Ethernet
Setup & Calibration	via front panel buttons or Windows software 'DOP 4'
Display	6 digit 7 segments, green LED's, 5.08mm, 8 status LED green, spectral filter 565 nm for improved contrast
Keyboard	4 pcs, \varnothing 3mm robust, for setup / calibration, zero, tare
Power supply	10 ... 30 VDC, < 4.0 W @ 24 VDC
Environmental Conditions	
Operating temperature	-15 $^{\circ}$ C to +55 $^{\circ}$ C at maximal 85% rh, non condensing
Storage temperature	-30 $^{\circ}$ C to +70 $^{\circ}$ C
Enclosure & protection	Plastic housing, for DIN rail mount (TS35) , protection IP40
Dimensions and weight	120 x 102 x 23 mm (L x H x W), weight approx. 170 g
Vibration resistance	2.5g @ operation, 5g @ storage
Service Port	
Protocol & Address range	RS 232, 9600 ... 460800 Baud – half/full duplex
Protocol & Address range	ASCII; address range 1 ... 255
Ethernet Ports (2 pcs.)	
Duplex modes	RJ45, 10/100 Mbit/s, integrated 2 port switch, isolated
Duplex modes	Half Duplex, Full Duplex, Auto-Negotiation
MDI modes	MDI, MDI-X, Auto-MDIX
Data transport layer	Ethernet II, IEEE 802.3
Analog current output (143.1 only)	0 – 20mA or 4 – 20mA, 500ohm, isolated or
Analog voltage output (143.1 only)	0 – 10V, 0 – 5V, ± 5 V, ± 10 V, 10kohm, isolated
Digital logic inputs	2 inputs (10 – 30V, 1 – 3mA), common ground, isolated
Digital logic outputs	3 outputs (semiconductor relays) 30 V DC/AC, 0.5 A, common ground, isolated

3. Hardware, Wiring and Communication LED's

3.1. Housing & Terminals

Max [redacted]
 Min [redacted] T = - [redacted]
 e = d = [redacted]

 -15°C/+55°C

Part no: 143.101.5 Rev. 1
 Serial no: [redacted]
 TAC Value: [redacted]
 Made by Hauch&Bach ApS, Femarbykøket 6, 3540 Lyrngø, DK

Scale informations for 'legal for trade' use



Terminals of the DAD 143.x

3.2. Terminals Load Cell Connection

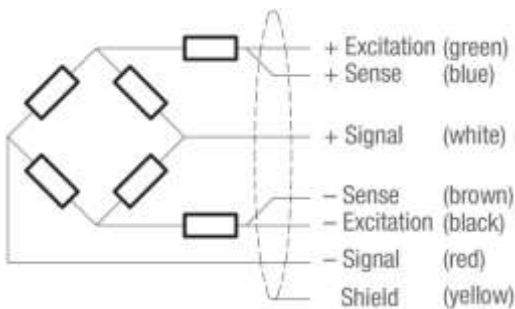
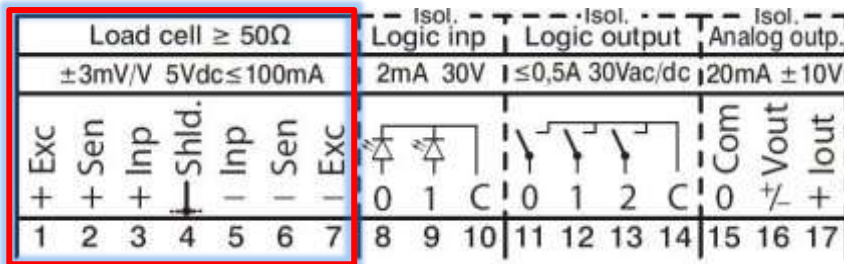

Colour code of e.g. standard load cells

DAD 143.x	Load cell input	Function
Pin no.		
1	+ Exc	+ Excitation for load cell
2	+ Sen	+ Sense for load cell
3	+ Inp	+ Signal of load cell
4	Shld.	Shield load cell
5	- Inp	- Signal of load cell
6	- Sen	- Sense for load cell
7	- Exc	- Excitation for load cell

3.3. Load Cell Connection

The load cell wiring should be made carefully before energizing to avoid damages to the amplifier and the load cells. The input resistance of the load cells that you want to connect should be $\geq 50 \Omega$ (ohms).

In case of using a load cell / scale with 4 wire cable, you have to short-circuit (bridge) the pins 1 & 2 and 6 & 7.

Remark: Please don't shorten the 4 wire cable of a load cell, as the cable is part of the factory calibration (signal & temperature compensation).

3.4. Terminals Power Supply

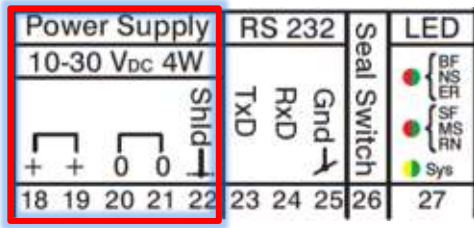

DAD 143.x	Power in	Function
Pin no.		
18	+	Power supply +12..24 V DC
19	+	Power supply +12..24 V DC
20	-	Common ground / 0 V DC
21	-	Common ground / 0 V DC
22	Shld.	Chassis ground

Depending on the grounding concept of the plant/scale, terminal 20 or 21 has to be connected to terminal 22. Terminal 4 (shld load cell) and 22 (Ground chassis) are internal connected.

Note: The power supply must be able to support about 200mA per DAD 143.x.

3.5. Terminals Service Port RS 232

The RS 232 port can be used for communication with a PC or PLC system.

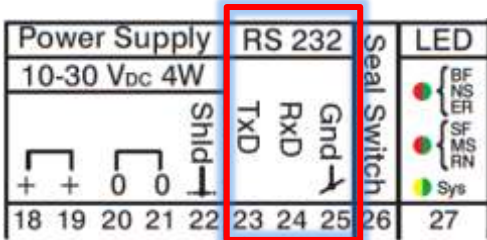

DAD 143.x	RS 232	Function
Terminal no.		
23	TxD	Transmit Data
24	RxD	Receive Data
25	GND	Signal ground RS 232

3.6. Ethernet Based Ports

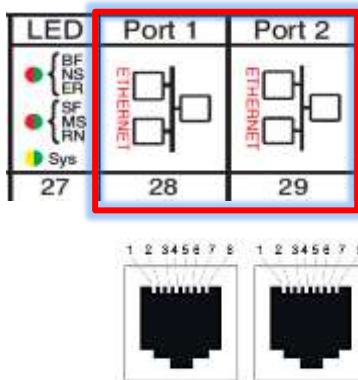

The two RJ45 Ethernet ports (28 & 29) are connected to an internal switch. The Ethernet ports support 10BASE-T and 100BASE-TX. Half-, Full- and auto negotiated duplex mode. MDI, MDI-X and Auto-MDIX crossover control.

Pin	Signal	Description
1	Tx+	Transmit data positive
2	Tx-	Transmit data negative
3	Rx+	Receive data positive
4	Term 1	Connected and terminated to "Shld" via RC combination *
5	Term 1	
6	Rx-	Receive data negative
7	Term 2	Connected and terminated to "Shld" via RC combination *
8	Term 2	

*Bob Smith termination

3.7. LED Indicators – Terminal 27

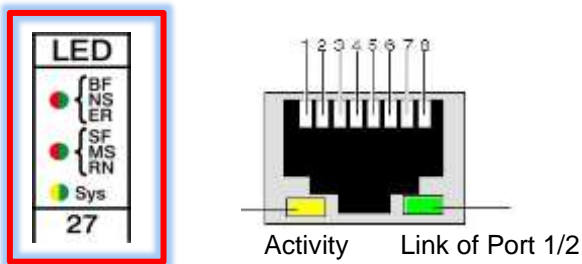

LED	Colour	State	Description
Sys	●	On	Protocol firmware running
	●	On or flashing	Service / maintenance firmware running in various modes
RN RUN	●	On	Connected – at least one TCP connection is established.
	●	Flashing, 1Hz	Ready but not configured
	●	Flashing, 5Hz	Configured and ready for communication
	○	Off	Not ready
ER ERR	○	Off	No errors
	●	Flashing, 2Hz	System error
	●	On	Communication error
Lnk1	●	On or flashing	Port 1 Ethernet link established
Act1	●	Flashing	Port 1 Ethernet Rx/Tx activity
Lnk2	●	On or flashing	Port 2 Ethernet link established
Act2	●	Flashing	Port 2 Ethernet Rx/Tx activity

Table of LED indicators for Modbus TCP protocol

3.8. Seal Switch

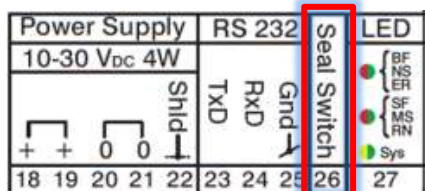

Setup or changes of calibration can only be performed with an open seal switch (26). Changes lead to get a new TAC value, increased by +1.

Running a legal for trade application needs the jumper connected to the switch pins and a seal. A broken seal shows up changes of calibration, which are not allowed.

➔ Protected commands see below.

Traceable Access Code (TAC) protected calibration commands

In case the seal switch is closed, the following commands or menus can't be proceeded:

- Calibration Zero
- Calibration Gain
- Calibration Absolute Zero
- Calibration Absolute Gain
- Calibration Minimum
- Calibration Maximum
- Zero Tracking
- Zero Range
- Display Step Size
- Decimal Point
- Calibration Save
- Factory Default
- Non Volatile Tare
- Non Volatile Zero
- Initial Zero @ power ON
- etc.

3.9. Logic Inputs & Outputs

The DAD143.x offers 2 isolated logic inputs and 3 isolated logic outputs, all “floating”.

The 2 inputs can e.g. get the function to act as the ZERO or TARE button, see chapter 8.10.

The 3 outputs act as switches for setpoints with hysteresis, switch behavior etc. Several reference values such as net weight, peak weight or average can be used, see chapter 8.11.

DAD143.x	Logic In- / Output	Function
Pin no.		
8	0	'High': +12 ... +24VDC
9	1	'High': +12...+24VDC
10	C	'Low' Common 0/1: 0V
11	0	Logic output 0
12	1	Logic output 1
13	2	Logic output 2
14	C	Common 0/1/2: 12 ... 24V oder 0V

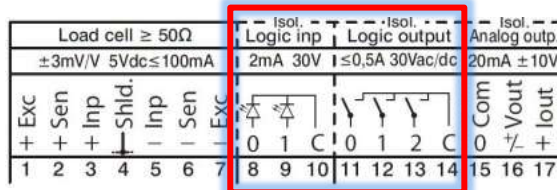

Note Logic Inputs:
The pulse duration must be at least 50ms.

Note Logic Outputs:
The connection C can be used for either 'high' level (24V AC/ DC) or 'low' level (0V).

3.10. Analog Outputs

The DAD143.1 offers 2 isolated analog outputs for current and voltage. For your application you can choose one of the six modes like:

- 4 to 20mA / 0 to 20mA
- 0 to +5V / 0 to +10V
- -5 to +5V / -10 to +10V.

DAD143.1	Analog Outputs	Function
Pin no.		
15	0 Com	Signal ground analog output
16	+/- Vout	Voltage output
17	Iout	Current output

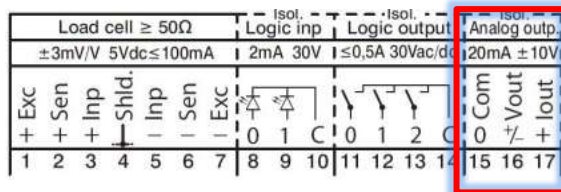

Note: The DAD143.2 has no analog outputs.

4. Communications and Getting started

4.1. Service Port

Communicating with the digital device DAD 143.x is carried out via serial service port RS 232. The data format is the familiar 8/N/1 structure (8 data bits, no parity, 1 stop bit). Available baud rates of RS 232 port are as follows: 9600, 19200, 38400, 57600, 115200, 230400 and 460800 baud.

Factory default: 115200 baud

4.2. Command Language

The command set of the DAD 143.x is based on a simple ASCII format (2 letters). This enables the user to setup the device, get results or check parameters.

Example: DAD 143.x is connected via the RS 232 port to a PC / PLC system. You want to get the identity, firmware version or net weight.

Remark: In this manual means: " " Space in the setup command and "↵" Enter (CR). Sending of a linefeed (LF) is not required and will be ignored by the device, if necessary.

Master (PC / SPS) sends	Slave (DAD 143.x) responds	Meaning
ID↵	D:1430	identity of the active device
IV↵	V:0140	Firmware version of the active device
GN↵	N+123.45	Net weight with algebraic sign; decimal point is fixed as setup with command DP

4.3. Baud Rate

For baud rate setup use the command BR, see chapter 8.11.2.

4.4. Getting Started via service port RS 232

You will require:

- PC or PLC with a RS 232 communication port
- A load cell / scale with test weights or a load cell simulator
- A 12 to 24 VDC power supply capable of delivering approximately 200mA for each DAD 143.x incl. the connected load cell(s).
- One or more DAD 143.x.
- A suitable ASCII communication software. **

Refer to the wiring diagrams in chapter 3.

**

You can easily communicate between a PC and a DAD 143.x using programs such as Procomm, Telemate, Kermit, HyperTerminal or HTerm etc.

Additional the very powerful software **DOP 4** (ver. 2.3.1.0 or higher) with graphical user interface and oscilloscope function for the operating systems Windows XP/Vista/7/8/10 is available.

Hint:

A download of a new firmware version can be done with the program Protocol Firmware Loader **PFL** ver. 1.00 or higher. The download has to be done via service port RS232 at a fixed baud rate of 115200. More details of this procedure see chapter 11 / page.62.

4.5. Getting Started via Ethernet based Port, e.g. Modbus TCP

Following steps outlined below simplify the process of setting up a system for the first time.

- Connect the DAD to a suitable power supply.
- Connect a Windows PC to the DAD 143.x service port through a RS232 COM port or an USB to RS232 converter.
- A terminal program e.g. HyperTerm can be used for verifying or changing the setup of the DAD 143.x. Default service port settings are: 115200 baud, 8 data bits, No parity and one stop bit.
- Or simply use the service commands for DAD 143.x of the Modbus TCP Viewer, see below.

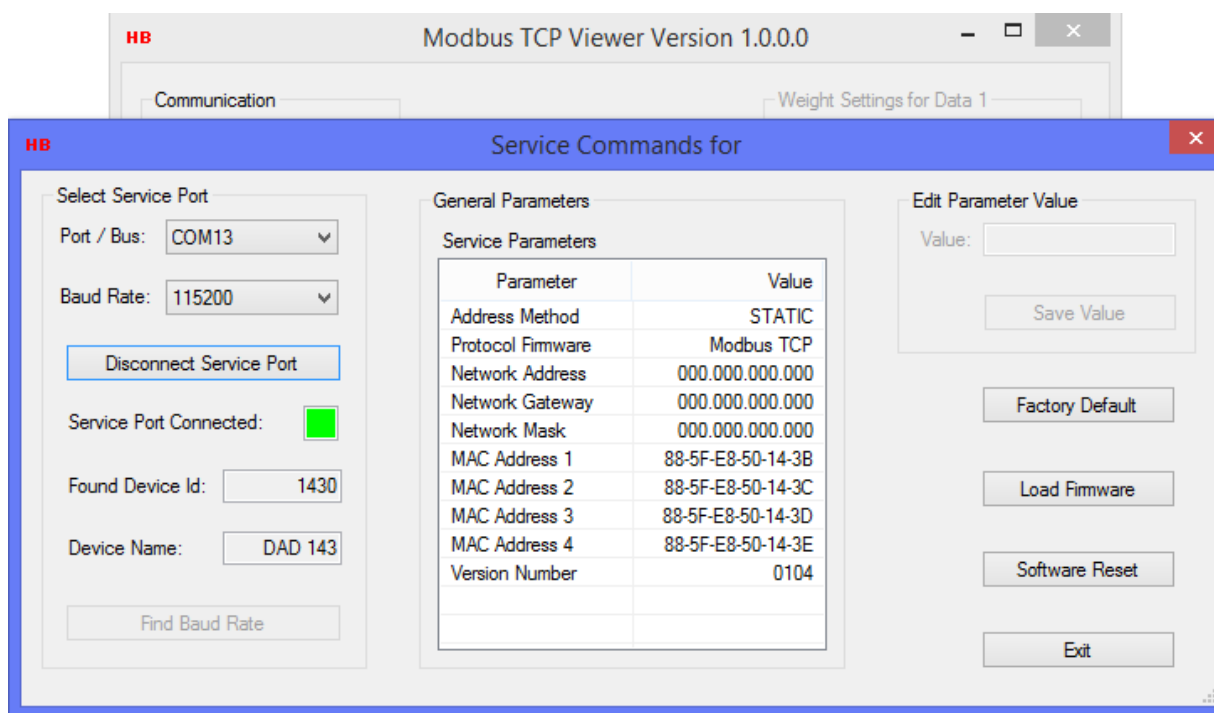

Screenshot of the Modbus TCP Viewer ver. 1.0.0.0 – Service Commands.

- Here you can edit the service parameters to the application needs.
- Make sure the protocol select (PS command) is set to “4” (Modbus TCP).
- Connect one of the DAD Ethernet ports to your network. The way the DAD 143.x obtain its IP address is by default set to DHCP. The use of this feature requires an Ethernet network with a DHCP server.
- For use the Modbus TCP protocol, you have to change the Address Method from DHCP to STATIC, which you can easily do via the service port.
- A Windows demo program for testing the Modbus TCP functionality can be downloaded here: <https://www.haubac.com/haubac.asp?p1=273>

See a screenshot of Modbus TCP Viewer version 1.0.0.0 or higher – see on next page.

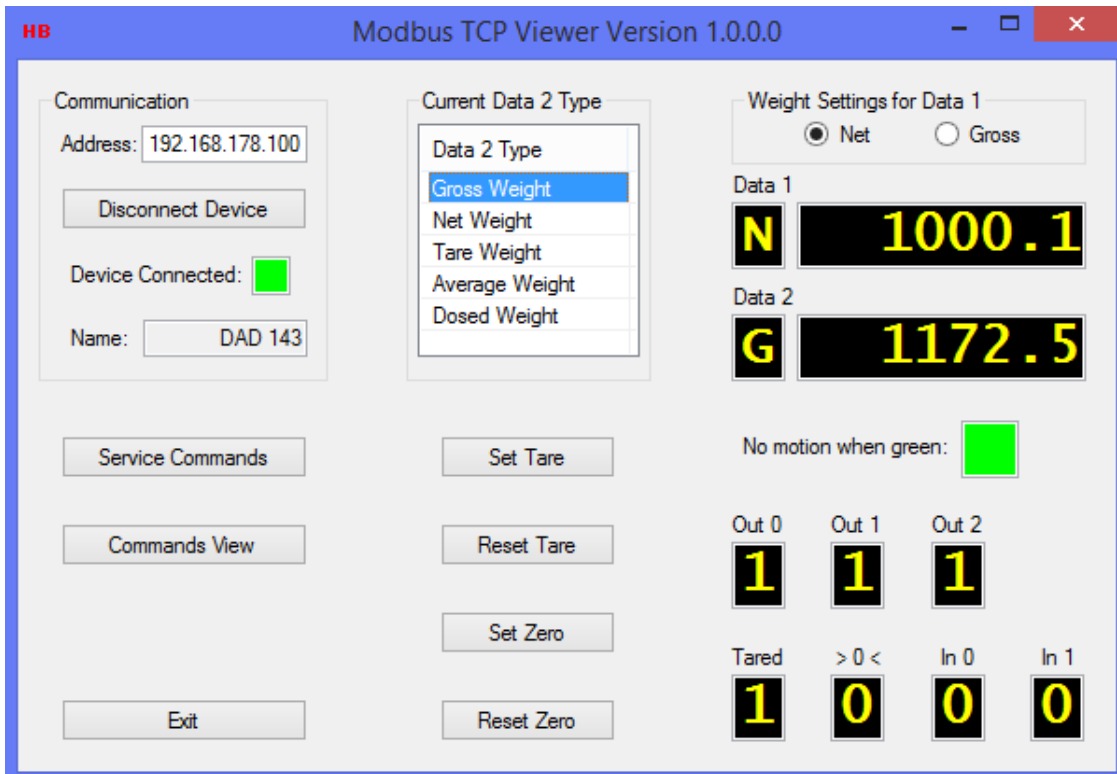

Screenshot of the Modbus TCP Viewer ver. 1.0.0.0

- This screenshot shows the Modbus TCP communication with 'Data 1' for presenting e.g. the Net Weight and 'Data 2' presenting the Gross Weight.
- Press the button 'Commands View', you get access to commands view with Index / Sub-Index etc. per command.

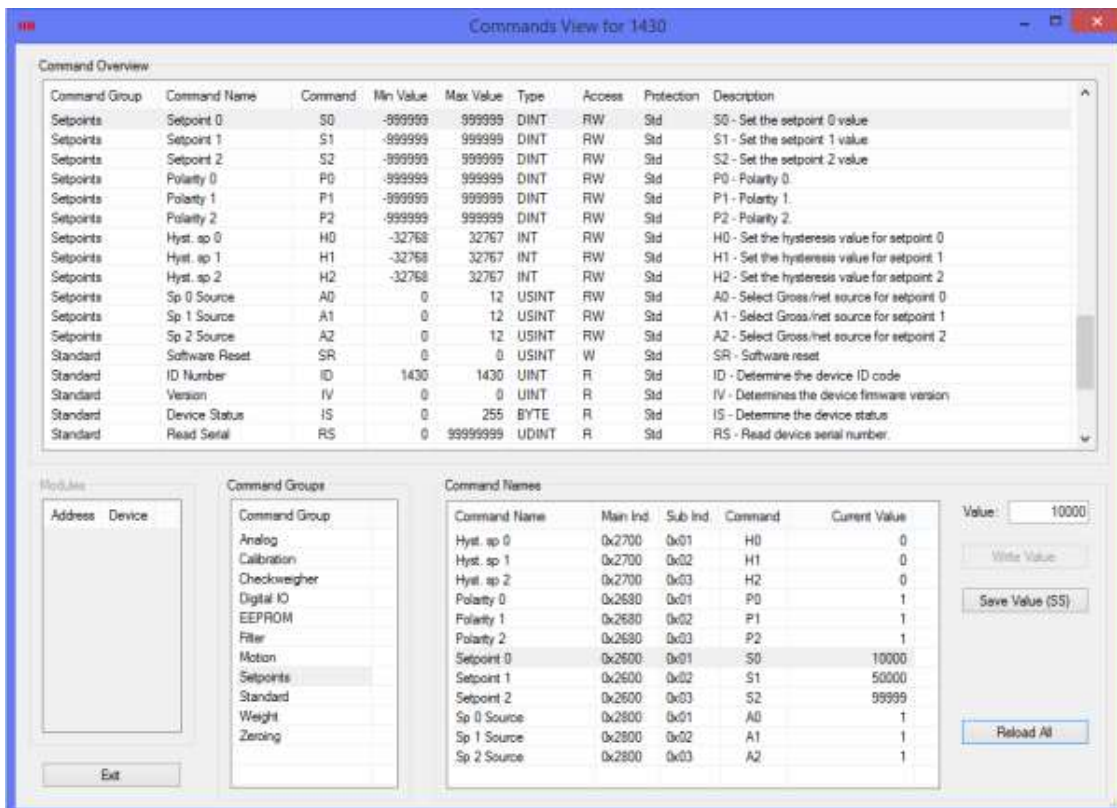

For starting with another Ethernet based communication, the procedure is similar.

For detailed technical information of the different PLC bus systems, please see individual manuals for # Profinet IO or # Ethernet/IP or # EtherCAT or # Modbus TCP.

6. Setup Via Front Panel Keyboard

6.1. Keyboard Buttons

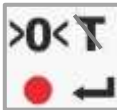

This is the ZERO button. This button can be used for zeroing in scale status 'NO Motion' within the setup limits and to clear TARE.

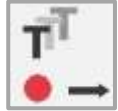

This is the TARE button. This button can be used for taring the scale in status 'NO Motion'.



The two UP/DOWN buttons will be used for setup via the menu.

6.2. Use of Keyboard Buttons



Press the UP or DOWN button for more than 3 seconds to enter the setup menu of front panel. In setup menu use these buttons to select one of the menus 1 to 8 and make your selection in the sub-menus or to setup single characters of the display.

Remark: To enable calibration – menu 1, 2 and 3 – you have to remove the jumper of seal switch (28). The TAC counter will increase by one after changes.



Enter in menu X to the different sub-menus of X. After choosing the setting with the UP or DOWN button, use this key again for storing. This is the ENTER button.

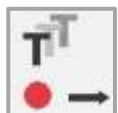

To leave menu X or sub-menu of X.
Leave with: press 1x TARE button for back to menu X.1 – 1st level
or press 2x TARE button for back to menu X

					Menu 7.0.1.1 – Setup Value 001000
X		Menu X	Select with UP / DOWN buttons Enter with ZERO button Leave with TARE button		X X
	X.1	Menu X - 1st level	Enter with ZERO button Select with UP / DOWN buttons Back with ZERO button Leave with TARE button		X
		X.1.1 Menu X - 2nd level	Enter with ZERO button Select with UP / DOWN buttons Enter with ZERO button Leave with TARE button		
		X.1.1.1 Menu X - 3rd level	Enter with ZERO button Select with UP / DOWN buttons Enter with ZERO button Use UP / DOWN buttons for single characters Use TARE button for next number Back with ZERO button Leave with: 1x TARE button back to menu X.1 2x TARE button back to menu X		X X X 0 0 1 0 0 0 x x x x x x X X

6.3. Menu 1 – System Zero

Remark: Activate a new calibration with 1x Power OFF & ON !

1.	ZERO setup (Menu 1.1 to 1.4)	TAC protected – see chapter 10.2.1
1.1	Automatic Zero Tracking - Enable / Disable	(command ZT)
	<ul style="list-style-type: none"> - Setting range: 0 ... 255 d - Disabled @ 00000, no ZERO Tracking - Enabled @ 00001 or higher (max 00255) - Setting 00001 sets a zero tracking range of $\pm 0.5d$ - Setting 00002 up to 00255 sets a zero track range of $\pm 1d$ up to $\pm 127.5d$, independent of decimal point setting 	
1.2	Calibrate system ZERO - gravimetric by weight / load	(command CZ)
	<ul style="list-style-type: none"> - Display shows the actual input signal in mV/V. - Press ENTER button to store ZERO. - Remark: Scale should/must be unloaded. 	
1.3	Calibrate system ZERO - electronic by mV/V value	(command AZ)
	<ul style="list-style-type: none"> - Use the UP/DOWN & MOVE RIGHT keys to setup the mV/V value at which the device should read ZERO 	
1.4	System ZERO & TARE function	
1.4.1	Store TARE value non volatile: ON / OFF	(command TN)
	<ul style="list-style-type: none"> - ON: store non-volatile @ power OFF - OFF: delete @ power OFF 	
1.4.2	Store ZERO value non volatile: ON / OFF	(command ZN)
	<ul style="list-style-type: none"> - ON: store non-volatile @ power OFF - OFF: delete @ power OFF 	
1.4.3	Initial ZERO @ power ON: ON / OFF	(command ZI)
	<ul style="list-style-type: none"> - ON: proceed initial Zero @ power ON - Range is $\pm 10\%$ of Max 	
1.4.4	ZERO range (increments)	(command ZR)
	<ul style="list-style-type: none"> - Set the zero setting range in divisions. - The setting is independent of decimal point setting. - Disabled @ 00000, no ZEROing possible - Enabled @ 00001 or higher (max 999999) <p>In a legal for trade application, the standard value is $\pm 2\%$ of Max. The setup for a scale with 3 000e is i.e.:</p> <ul style="list-style-type: none"> - Max (CM) = 1 500 kg - Step Size (SZ) = 0.5 kg - Zero Range (ZR) of $\pm 2\%$ = ± 30 kg, which is ± 60 d. 	

6.4. Menu 2 – System Span

Remark: Activate a new calibration with 1x Power OFF & ON !

2.		SPAN setup (Menu 2.1 to 2.4)	TAC protected – see chapter 10.2.1
2.1		Set SPAN Calibration value	(command CG)
		- Set display value equivalent to calibration weight or to mV/V value derived from load cell(s) test data.	
2.2		Calibrate system SPAN - gravimetric by weight / load	
		- Display shows the actual input signal in mV/V.	
		- Apply test weight equivalent to calibration value (2.1).	
		- Press ENTER button to store new SPAN signal.	
2.3		Calibrate system SPAN - electronic by mV/V input	(command AG)
		- Use the UP/DOWN & MOVE RIGHT keys to setup the mV/V value at which the device should read SPAN.	
		- Press ENTER button to store new SPAN signal.	
2.4		Display the input signal in mV/V	
		- This function displays the actual input signal of the load cell(s).	
2.5		Display the firmware version, e.g. 1.47	(command IV)
		- Read and display the firmware version.	
2.6		Display the actual TAC value, e.g. 34	(command CE)
		- Read and display the TAC value of the actual calibration.	

6.5. Menu 3 – Display

Remark: Activate a new calibration with 1x Power OFF & ON !

3.		Display setup (Menu 3.1 to 3.4) TAC protected – see chapter 10.2.1
	3.1	Display limits - Overrange / Underrange (commands CMn/CI)
	3.1.o1	Display overrange limit CM1 (maximum value +999999) (CM1) Use the UP/DOWN & MOVE RIGHT keys to setup the maximum display value, above which the display shows over range (all dashes in the top of the display).
	3.1.o2	Display overrange limit CM2 (maximum value +999999) (CM2)
	3.1.o3	Display overrange limit CM3 (maximum value +999999) (CM3)
	3.1.U	Display underrange limit (minimum value -999999) (CI) Use the UP/DOWN & MOVE RIGHT keys to setup the minimum display value, above which the display shows under range (all dashes in the bottom of the display).
	3.2	Display step size - in digits [d] (command DS)
	-	choose one out of 1, 2, 5, 10, 20, 50, 100, 200, 500
	3.3	Decimal point position on the display (command DP)
	-	choose one out of 0, 0.0, 0.00, 0.000, 0.0000, 0.00000
	3.4	Setup of Multi-interval or Multi-range (command MR)
	-	Choose 0 for Multi-interval or 1 for Multi-range scale.

6.6. Menu 4 – Filter & Motion Detection

Remark: Activate a new setup with 1x Power OFF & ON !

4	Digital filter & No Motion setup (Menu 4.1 to 4.4)	
4.1	Low pass filter cut off frequency (command FL)	
	- Settings: 0 - 8 with UP/DOWN buttons	
4.1.x	Cut off frequency:	
	IIR mode	FIR mode
4.1.0	No digital filter	No digital filter
4.1.1	18 Hz	19.7 Hz
4.1.2	8 Hz	9.8 Hz
4.1.3	4 Hz	6.5 Hz
4.1.4	3 Hz	4.9 Hz
4.1.5	2 Hz	3.9 Hz
4.1.6	1 Hz	3.2 Hz
4.1.7	0.5 Hz	2.8 Hz
4.1.8	0.25 Hz	2.5 Hz
4.2	Digital filter Mode - IIR or FIR (command FM)	
	- Choose IIR or FIR	
4.3	Update rate and averaging (command UR)	
4.3.x	Averaging (from 1 to 128 readings)	
4.3.0	0 - each reading	
4.3.1	1 - average of 2 readings	
4.3.2	2 - average of 4 readings	
4.3.3	3 - average of 8 readings	
4.3.4	4 - average of 16 readings	
4.3.5	5 - average of 32 readings	
4.3.6	6 - average of 64 readings	
4.3.7	7 - average of 128 readings	
4.4	Motion detection	
4.4.1	No motion range (value range from 1 to 65 535 d) (command NR)	
	Weight value changes within this range will be considered as 'stable'	
4.4.2	No motion time (value range from 1 to 65 535 ms) (command NT)	
	Time span for the no motion detection where the signal has to be 'stable'	

6.7. Menu 5 – Analog Output

Remark: Activate a new setup with 1x Power OFF & ON !

5	Analog output setup (Menu 5.1 to 5.5)												
5.1	<p>Weight value for minimum analog output (command AL)</p> <ul style="list-style-type: none"> - Set the weight value which corresponds to minimum output <p>Examples for scale 0 ... 3 000kg</p> <p>Minimum 0kg or with 600kg preload</p> <ul style="list-style-type: none"> - output mode 4 ... 20mA: 0kg = 4mA - setting 00000 600kg = 4mA - setting 00600 - output mode 0 ... 20mA: 0kg = 0mA - setting 00000 600kg = 0mA - setting 00600 												
5.2	<p>Weight value for maximum analog output (command AH)</p> <ul style="list-style-type: none"> - Set the weight value which corresponds to maximum output <p>Examples for scale 0 ... 3 000kg</p> <p>Maximum 3 000kg</p> <ul style="list-style-type: none"> - output mode 4 ... 20mA: 3 000kg = 20mA - setting 03000 - output mode 0 ... 20mA: 3 000kg = 20mA - setting 03000 												
5.3	<p>Analog output base (command AA)</p> <p><i>Gr05</i> - analogue output follows Gross value <i>nEt</i> - analogue output follows Net value <i>PEA</i> - analogue output follows Peak value (Maximum) <i>AUEr</i> - analogue output follows Average value <i>HoLd</i> - analogue output follows Hold value <i>PP</i> - analogue output follows Peak - Peak value <i>URLL</i> - analogue output follows Valley value (Minimum) <i>d iSP</i> - analogue output follows Display value <i>oFF</i> - analogue output is switched OFF <i>rEF</i> - analogue output follows a set reference value, cmd AR</p>												
5.4	<p>Analog output mode (command AM)</p> <table border="1"> <tr> <td>4_20</td> <td>4 to 20mA</td> </tr> <tr> <td>0_20</td> <td>0 to 20mA</td> </tr> <tr> <td>0_5</td> <td>0 to +5V</td> </tr> <tr> <td>0_10</td> <td>0 to +10V</td> </tr> <tr> <td>-5_5</td> <td>-5 to +5V</td> </tr> <tr> <td>-10_10</td> <td>-10 to +10V</td> </tr> </table>	4_20	4 to 20mA	0_20	0 to 20mA	0_5	0 to +5V	0_10	0 to +10V	-5_5	-5 to +5V	-10_10	-10 to +10V
4_20	4 to 20mA												
0_20	0 to 20mA												
0_5	0 to +5V												
0_10	0 to +10V												
-5_5	-5 to +5V												
-10_10	-10 to +10V												
5.5	<p>Setup of test signal current or voltage analog output</p> <p>The test signal, independent of the measuring signal, is based on the chosen mode in menu 5.4. The setup uses 6 digits, e.g. 004.000 for 4mA (decimal point position is fixed). For each mode you can use the output range plus +/- 0.1 ! Setup of a negative value via left figure/"-" sign (left status LED).</p>												

6.8. Menu 6 – Logic Inputs

Remark: Activate a new setup with 1x Power OFF & ON !

6	Logic input setup (Menu 6.0 to 6.1)
6.0	Logic Input "0" (command AI'n' – n=0)
6.0.x	Functions (x = choose one from 00 to 18 with 'up'/'down' buttons) <ul style="list-style-type: none"> 00 - Input "0" has no function 01 - Input "0" acts as Zero button 02 - Input "0" acts as Tare button 03 - Input "0" acts as Up arrow button 04 - Input "0" acts as Down arrow button 05 - Input "0" starts the Trigger function 06 - Input "0" displays the Average value 07 - Input "0" displays the Peak value (maximum) 08 - Input "0" deletes the Peak value (maximum) 09 - Input "0" displays the Hold value 10 - Input "0" displays the Peak to Peak value 11 - Input "0" displays the Valley value (minimum) 12 - Input "0" disables the buttons 13 - Input "0" stores the actual weight (Hold) value 14 - Input "0" tares the displays and deletes all other values 15 - Input "0" turn off display
6.1	Logic Input "1" (command AI'n' – n=1)
6.1.x	Functions (x = choose one from 00 to 18 with 'up'/'down' buttons) <ul style="list-style-type: none"> 00 - Input "1" has no function 01 - Input "1" acts as Zero button 02 - Input "1" acts as Tare button 03 - Input "1" acts as Up arrow button 04 - Input "1" acts as Down arrow button 05 - Input "1" starts the Trigger function 06 - Input "1" displays the Average value 07 - Input "1" displays the Peak value (maximum) 08 - Input "1" deletes the Peak value (maximum) 09 - Input "1" displays the Hold value 10 - Input "1" displays the Peak to Peak value 11 - Input "1" displays the Valley value (minimum) 12 - Input "1" disables the buttons 13 - Input "1" stores the actual weight (Hold) value 14 - Input "1" tares the displays and deletes all other values 15 - Input "1" turn off display

6.9. Menu 7 – Logic Outputs

Remark: Activate a new setup with 1x Power OFF & ON !

7	Logic output setup (Menu 7.0 to 7.2)	
7.0	Logic Output "0"	
7.0.1	Setpoint "0"	
7.0.1.1	Setup of the Setpoint value Permitted values +/- 999 999	(command S'n' – n=0)
7.0.1.2	Setup the Polarity (switch logic) ON or OFF Use the UP/DOWN buttons for "on" / "oFF"	(command P'n' – n=0)
7.0.2	Hysterisis value "0" (\pm 'n') Permitted values -32 768 ... +32 767	(command H'n' – n=0)
7.0.3	Base for Setpoint "0" <i>Gross</i> - Gross value <i>Net</i> - Net value <i>PEAK</i> - Peak value (Maximum) <i>AVER</i> - Average value <i>Hold</i> - Hold value <i>PP</i> - Peak to Peak value <i>VALLEY</i> - Valley value (Minimum) <i>ERROR</i> - Error 4 or 5	(command A'n' – n=0)
7.0.4	Test logic output "0" (Use the UP/DOWN buttons) Open/Close contacts using the keyboard	
7.0.4.0	Output is OFF	
7.0.4.1	Output is ON	
7.1	Logic Output "1" As per section 7.0 - but for logic output "1"	(commands S'n', P'n', H'n', A'n' – n=1)
7.2	Logic Output "2" As per section 7.0 - but for logic output "1"	(commands S'n', P'n', H'n', A'n' – n=2)
7.3	Hold Time for <u>all</u> the Logic Outputs 0, 1 and 2 Permitted value range is from 0 to 65 535 ms The signal has to exceed the setpoint limit continuously at least for this time period before a switch event will be initiated.	(command HT)

6.10. Menu 8 – Data Communication

Remark: Activate a new setup with 1x Power OFF & ON !

8	Data Communication setup (Menu 8.1 to 8.9)	
8.1	Baud Rate for Service Port RS 232 (use the UP/DOWN buttons) (command BR)	
	<p style="text-align: center;">9600 Baud 19200 Baud 38400 Baud 57600 Baud 115200 Baud 230400 Baud 460800 Baud</p>	
8.2	Address setting for RS232 (use the UP/DOWN buttons)	
	Address range is 0 ... 255	
8.3	Select Auto-transmit mode (use the UP/DOWN buttons) (command AT)	
	<p><i>oFF</i> - set output "1" OFF <i>GrO5</i> - Gross value (command SG) <i>nEt</i> - Net value (command SN) <i>AUEr</i> - Average value (command SA) <i>SRP</i> - ADC value <i>ALL</i> - Data string with Gross, Net and Status (command SW) <i>PEAK</i> - Peak value (Maximum) (command SM) <i>hOLd</i> - Hold value (command SH) <i>VALL</i> - Valley value (Minimum) (command SV) <i>PP</i> - Peak to Peak value (command SO) <i>REd</i> - Data string compatible to AED (HBM)</p>	
8.4	IP Address , depending on protocol * (use the UP/DOWN buttons)	
	- Static addressing in menu 8.7 required	
8.4.y	Modbus TCP (factory default), for INSPECTION and SETTING via front panel:	
8.4.1	Setting	000000
8.4.2	Setting	000000
8.4.3	Setting	000000
8.4.4	Setting	000000
8.5	Network Mask , depending on protocol * (use the UP/DOWN buttons)	
	- Static addressing in menu 8.7 required	
8.5.y	Modbus TCP (factory default), for INSPECTION and SETTING via front panel:	
8.5.1	Setting	000000
8.5.2	Setting	000000
8.5.3	Setting	000000
8.5.4	Setting	000000

Menu 8 – Data Communication / Continuation

8	Data Communication setup (Menu 8.6 to 8.9)
8.6	Gateway Address , depending on protocol * (use the UP/DOWN buttons) - Static addressing in menu 8.7 required
8.6.y	Modbus TCP (factory default), for INSPECTION and SETTING via front panel:
8.6.1	Setting 000000
8.6.2	Setting 000000
8.6.3	Setting 000000
8.6.4	Setting 000000
8.7	Select the addressing mode * (use the UP/DOWN buttons)
	<p>Modbus TCP select: <i>dhcP</i> or <i>StAt ic</i> or <i>bootP</i></p>
8.8	Protocol Selection for Port 1 & 2 (use the UP/DOWN buttons)
	<p><i>Pr i o</i> – ProfiNet <i>Et n IP</i> – Ethernet/IP <i>Et cAt</i> – EtherCAT <i>t cP</i> – Modbus TCP</p> <p>Remark: changing the protocol means an automatic ‘re-start’ of the DAD 143.x!</p>
8.9	Save or Restore user setup (use the UP/DOWN buttons) (commands SU / RU)
	<p>STORE – Store setup in EEPROM RECALL – Restore setup from EEPROM</p> <p>Remark: After RECALL, for activation you have to re-start the DAD 143.</p>

* Notes for the different protocols:

- **ProfiNet:** Menu 8.4.y, 8.5.y and 8.6.y can be used for inspection of the IP address, the network mask and the default gateway address, but are not allowed to change settings via front panel. Menu 8.7 not in use.
- **Ethernet/IP:** Menu 8.4.y, 8.5.y and 8.6.y can be used for inspection **and** setting of the IP address, the network mask and the default gateway address. Settings of these values will make sense only if STATIC addressing is selected in menu 8.7.
- **EtherCAT:** Menu 8.4.y, 8.5.y and 8.6.y are not using IP addresses. These settings have no meaning for this protocol and are shown as “-----” for these menu settings.
In menu 8.7 select a device identification number between 0 and 65535.
- **Modbus TCP:** Menu 8.4, 8.5 and 8.6 can be used for inspection **and** setting of the IP address, the network mask and the default gateway address. Settings of these values will make sense only if STATIC addressing is selected in menu 8.7.

6.11. Factory Default via Front Panel



While Power ON the DAD 143, press the both buttons UP & DOWN simultaneously for 2 or 3 seconds for setting the device to factory default.

Note: All settings will be deleted proceeding a factory default!

6.12. Error Codes - shown in the Front Panel Display

	Zero key is not enabled (chapter 7.3, menu 1.1)
	Out of zero range. (You are trying to set a zero which is greater than $\pm 2\%$ of the upper display limit)
	N/A
	Input exceeded $\pm 3.3\text{mV/V}$
	Load cell connection fail
	Requested value out of range
	Display overload – see menu 3.1o
	Display underload – see menu 3.1u
	The Zero or Tare motion limit has been exceeded. Set Zero or Tare function disallowed. Review Zero and Tare motion limits set in menu 4.4.

7. Examples of calibration

7.1. Example 1 – Calibration procedure using weights

3 Leg tank or silo fitted with 3 load cells of 1000kg;
load cell signal @ 1000kg = 2 mV/V.

Dead load of tank / silo is 600kg.
Live range is 1 500kg, step size is 0.5kg.

It is assumed that the load cell system is connected to the DAD 143.x and the power is on. The maximum and minimum display values, display increment size and decimal point position should be defined prior to carrying out the calibration (See chapter 7.5 menu 3).

For this example the display maximum is defined as 1600.0kg, the display minimum is -200.0kg, the Display step size is 0.5kg.

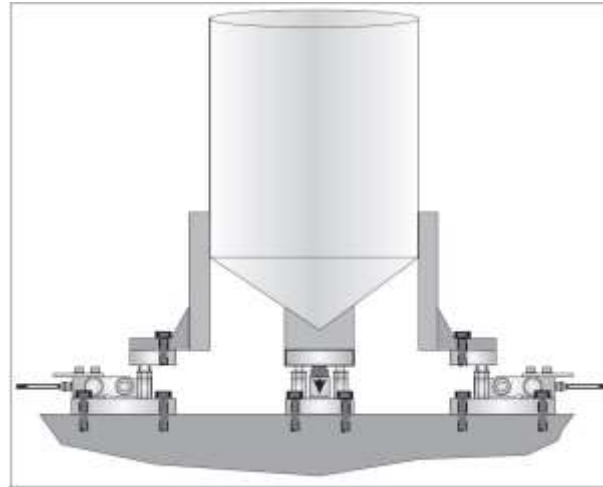

Remember that all parameters of the menus 1.1 - 1.3, 2.1 - 2.3 and 3.1 - 3.3 can only be accessed or changed after remove the jumper on the seal switch pins (28).

- a** A scale calibration by using weight(s) can only be performed in the scale status 'no motion'. This requires in any case to check the settings of menu 4.

Recommendations for setup as follows:

- Menu 4.1: set cut off frequency to 4.1.7 = 0.5Hz
- Menu 4.2: choose IIR filter
- Menu 4.4.1: set no motion range e.g. to 2, which means for this example 0.2kg
- Menu 4.4.2: set no motion time to 1000, which means 1000ms or 1s

In case of outdoor application or indoor with a lot of mechanical noise from the floor/ground, may be you have to change the 'no motion' settings.

- b** Go to Menu 3.2 (display step size) by using the **UP/DOWN** and **ZERO** keys. The display shows the actual step size, e.g. 1. Now you can change step size by using the **UP/DOWN** keys and set to 5. Press the **ZERO** key to store & leave menu point. This procedure defines the step size to 5, which leads with the setup of decimal point to 0.5kg steps.
- c** Go to Menu 3.3 (decimal point position) by using the **UP/DOWN** and **ZERO** keys. The display shows the actual decimal point, e.g. 0.0. Now you could change decimal point position by using the **UP/DOWN** keys, but in this example we keep the setup. Press the **ZERO** key to store & leave menu point. This procedure defines the decimal point position to 0.0, which leads to weight readings of e.g. 498.5kg.
- d** Go to Menu 1.2 by using the **UP/DOWN** and **ZERO** keys. The display shows the actual mV/V value, e.g. 0.4107. Make sure that the tank/silo is empty or at the point where you want the display to read zero. Press the **ZERO** key to set the display to read 0000.0kg. This procedure defines the actual zero calibration point. Leave this menu point with **ZERO** key.
- e** Go to Menu 2.1 by using the **UP/DOWN** and **ZERO** keys. Set the display to read the span value of the calibration weight(s) applied. For this example, if the calibration applied load is 750kg, set the display to read 750.0. By using the **UP/DOWN** and **TARE** keys you have to setup each number of the 6 digit display to 00750.0. Press now **ZERO** key for storage. This procedure defines the span calibration value. Leave this menu point with **ZERO** key.
- f** Go to Menu 2.2. by using the **UP/DOWN** and **ZERO** keys. Apply the calibration weight(s) to the weighing system. The display will show the actual input signal in mV/V, e.g. 0.9087. Press the **ZERO** key to set the display to read 750.0kg. The gravimetric calibration is done. Leave this menu point with **ZERO** key.

- g** The last point for this example are the settings of over/under range.
Go to Menu 3.1 (over/under range) by using the **UP/DOWN** and **ZERO** keys.
Press **ZERO** key again for setup over range (3.1.o) or additional with **UP** key under range (3.1.U).
The display shows in both cases 099999.9. By using the **UP/DOWN** and **TARE** keys you have to setup each number of the 6 digit display to 01600.0 for over range and 00200.0 for under range. As default, the under range value is always negative, shown trough the '-' LED in the display (left lower corner).
Leave each menu point with the **ZERO** key.
This procedure defines the over range to 1600.0, which leads @ weight readings of >1600.0kg to all upper LEDs of the 6 display numbers.
This procedure defines the under range to -200.0, which leads @ weight readings of <-200.0kg to all lower LEDs of the 6 display numbers.

Press the **TARE** key two or three times and the DAD 143.x will be back in weighing mode.

Calibration is now completed and stored. Please switch 1x OFF/ON for new TAC value.

Remark

After calibration procedure you can adjust the filter settings back to your application.
As rule of thumb you can calculate the weight/force true value of nearly 100% as $1/\text{cut off frequency}$.

Examples:

- $f_{\text{cut}} = 0.5 \text{ Hz}$ means it takes about 2 seconds for the true value – the value will increase while these 2 seconds to the true value.
- $f_{\text{cut}} = 8 \text{ Hz}$ means it takes about 0.125 seconds for the true value – the value increase take only 125 milliseconds.

7.2. Example 2 – Calibration procedure using load cell's mV/V sensitivity

3 Leg tank or silo fitted with 3 load cells of 1000kg;
load cell signal @ 1000kg = 2 mV/V.

Dead load of tank / silo is 600kg.
Live range is 1500 kg, step size is 0.5kg.

It is assumed that the load cell system is connected to the DAD 143.x and the power is on. The maximum and minimum display values, display increment size and decimal point position should be defined prior to carrying out the calibration (See chapter 7.5 menu 3).

For this example the display maximum is defined as 1600.0kg, the display minimum is -200.0kg, the Display step size is 0.5kg.

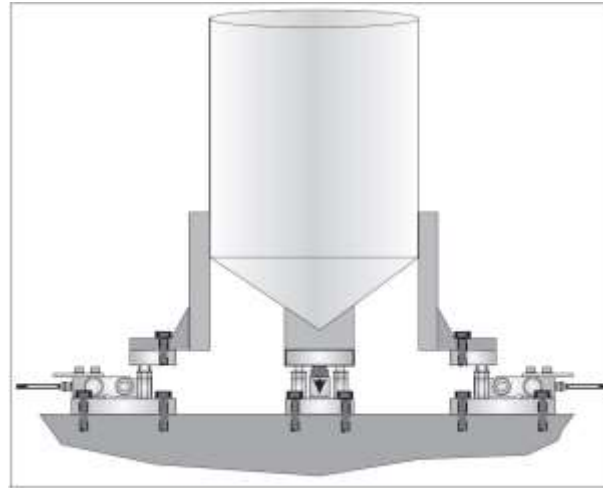

Remember that all parameters of the menus 1.1 - 1.3, 2.1 - 2.3 and 3.1 - 3.3 can only be accessed or changed after remove the jumper on the seal switch pins (28).

- a** A scale calibration by using weight(s) can only be performed in the scale status 'no motion'. This requires in any case to check the settings of menu 4.

Recommendations for setup as follows:

- Menu 4.1: set cut off frequency to 4.1.7 = 0.5Hz
- Menu 4.2: choose IIR filter
- Menu 4.4.1: set no motion range e.g. to 2, which means for this example 0.2kg
- Menu 4.4.2: set no motion time to 1000, which means 1000ms or 1s

In case of outdoor application or indoor with a lot of mechanical noise from the floor/ground, may be you have to change the 'no motion' settings.

- b** Go to Menu 3.2 (display step size) by using the **UP/DOWN** and **ZERO** keys. The display shows the actual step size, e.g. 1. Now you can change step size by using the **UP/DOWN** keys and set to 5. Press the **ZERO** key to store & leave menu point. This procedure defines the step size to 5, which leads with the setup of decimal point to 0.5kg steps.
- c** Go to Menu 3.3 (decimal point position) by using the **UP/DOWN** and **ZERO** keys. The display shows the actual decimal point, e.g. 0.0. Now you could change decimal point position by using the **UP/DOWN** keys, but in this example we keep the setup. Press the **ZERO** key to store & leave menu point. This procedure defines the decimal point position to 0.0, which leads to weight readings of e.g. 498.5kg.
- d** Go to Menu 1.3 (cal. zero in mV/V) by using the **UP/DOWN** and **ZERO** keys. The display shows the actual mV/V value, e.g. 0.4107. Make sure that the tank/silo is empty or at the point where you want the display to read zero. Press the **ZERO** key to set the display reading to 0000.0kg. This procedure defines the actual zero calibration point. Leave this menu point with **ZERO** key.

In case you want to setup absolute zero to 00.0000mV/V, you can do this via **ZERO** key and using **UP/DOWN** and **TARE** keys etc.

- e** Go to Menu 2.1 by using the **UP/DOWN** and **ZERO** keys. Set the display to read the span value @ summary of load cell capacity. For this example, we use 3 load cells with 1000kg capacity each, set the display to read 3000.0. By using the **UP/DOWN** and **TARE** keys you have to setup each number of the 6 digit display to 03000.0. Press now **ZERO** key for storage. This procedure defines the span calibration value. Leave this menu point with **ZERO** key.

f Go to Menu 2.3. by using the **UP/DOWN** and **ZERO** keys. The display shows 00.000mV/V. The load cells signal @ 3000kg is e.g. 2.0123mV/V ((signal #1 + signal #2 + signal #3) / 3). By using the **UP/DOWN** and **TARE** keys you have to setup each number of the 6 digit display to 02.0123. Press the **ZERO** key to set the display to read 3000.0kg. The electronic span calibration is done.
Leave this menu point with **ZERO** key.

The mV/V setting conform to our example with 1500kg live range means, we would have to setup only 01.0062 – which is 50% of mV/V @ 3000kg.

g The last point for this example are the settings of over/under range.
Go to chapter 7.4 menu 3.1 (over/under range) by using the **UP/DOWN** and **ZERO** keys.
Press **ZERO** key again for setup over range (3.1.o) or additional with **UP** key under range (3.1.U).
The display shows in both cases 099999.9. By using the **UP/DOWN** and **TARE** keys you have to setup each number of the 6 digit display to 01600.0 for over range and 00200.0 for under range. As default, the under range value is always negative, shown trough the '-' LED in the display (left lower corner).
Leave each menu point with the **ZERO** key.
This procedure defines the over range to 1600.0, which leads @ weight readings of >1600.0kg to all upper LEDs of the 6 display numbers.
This procedure defines the under range to -200.0, which leads @ weight readings of <-200.0kg to all lower LEDs of the 6 display numbers.

Press the **TARE** key two or three times and the DAD 143.x will be back in weighing mode.

Calibration is now completed and stored. Please switch 1x OFF/ON for new TAC value.

Remark

After calibration procedure you can adjust the filter settings back to your application.
As rule of thumb you can calculate the weight/force true value of nearly 100% as 1/cut off frequency.

Examples:

- fcut = 0.5 Hz means it takes about 2 seconds for the true value – the value will increase while these 2 seconds to the true value.
- fcut = 8 Hz means it takes about 0.125 seconds for the true value – the value increase take only 125 milliseconds.

Practicle Hint

A mix between gravimetric & electronic calibration is possible, too. For silos or tanks can a complete gravimetric calibration lead to a problem when you have to apply e.g. 50 tons. In such a case we recommend to calibrate zero gravimetrically (dead load of silo / tank) and span electronically (average mV/V values of load cells).

8. Setup via PC / PLC - Command Overview -

Command	Short description	Parameter value	Page
AA	Get/set analog output action (base)	0 through 10	55
AD	Communication: Device Address	0...255	54
AG	Absolute gain calibration	± 33000	41
AH	Get/set analog high	-999999 to 999999	55
AI'n'	Assign Input 'n' to 1 out of 15 different functions/base	0 to 15	50
AL	Get/set analog low	-999999 to 999999	55
AM	Analog Output Mode Current / Voltage	0 to 5	56
A'n'	Action for Setpoint 'n': choose 0 of 8 different base for setpoint 'n'	0 to 8	52
AR	Reference value for analog output	-999999 to 999999	56
AP	Ethernet address assignment method	0 ... 2	64
AS	Save analog output parameters	none	57
AT	Auto transmit after Power ON	0...10 or 0...8	34
AV	Show the actual internal mV/V value	e.g. A+02645	39
AZ	Absolute zero point calibration	± 33000	41
BR	Communication: Baud Rate	9600...460800 baud	54
CE	Calibration: Open Calibration Sequence; Read TAC Counter	0...65535	37
CG	Calibration: Set Calibration Gain (Span) at Load > Zero	1...999999	39
CI	Calibration: Minimum Output Value	-999999...0	37
CL	Communication: Close Device	None	54
CM n	Calibration: Set Maximum Output Value (n = 1, 2 or 3)	1...999999	37
CS	Save the Calibration Data (CM, CI, DS, DP, etc.) to the EEPROM	None	41, 56
CV	Calibrate Value	999999	39
CZ	Calibration: Set Calibration Zero Point – Scale Without Load	None	38
DP	Calibration: Set Decimal Point Position	0...5	38
DS	Calibration: Set Display Step Size	1, 2, 5, 10, ..., 500	38
DX	Communication: Set full-duplex (1) or half duplex (0)	0 or 1	54
FD	Factory default settings: Write Data to the EEPROM (TAC protected)	None	39
FM	Read / modify filter mode: IIR (0) or FIR (1)	0 or 1	43
FL	Digital low pass filter: Filter Cut-off Frequency	0...8	44
FT	Firmware type, check weighing, weighing filler, dose out, loss in weight	0...3	42
FU	Firmware Update (program PFL.exe and file FWUPDATE.zip needed)	None	62
GA	Output: Get Triggered Average Value	None	48, 58
GG	Output: Get Gross Value	None	47
GH	Get Hold Value	None	49
GI	Retrieves an image file from the DAD143.x's EEPROM	None	57
GN	Output: Get Net Value	None	47
GM	Get Peak (Maximum) Value	None	49
GO	Get Peak tp Peak Value	None	49
GS	Output: Get ADC Sample Value	None	47
GT	Output: Get Tare Value	None	47
GV	Get Valley Value	None	49
GW	Output: Get Data String "Net/Gros/Status"	None	47
H'n'	Hysteresis for Setpoint H0 (S0) or H1 (S1) or H2 (S2)	-32768...+32767	52
HT	Trigger function: Hold time for Violation of Setpoint Limit	0...65535 ms	53
ID	Device information: Identify Device	None	36
IN	Logic input: for each Input Status 0 or 1	0000...0011	51
IO	Logic output: for each Output Status 0 or 1	0000...0111	51
IS	Device information: Identify Device Status	None	36
IV	Device information: Identify Firmware Version	None	36
LE	Last Error occurred in DAD143.x, showing a code between 0 and 15	None	35

Command	Short description	Parameter value	Page
MR	Calibration: Define Multi-interval (0) or Multi-range (1)	0 or 1	38
MT	Trigger function: Measuring Time for Averaging	0...3000 ms	57
MA	Show one (of the four) MAC addresses assigned to the DAD143.x	1 ... 4	65
NA	Network address (IP address) <aaa.bbb.ccc.ddd>	aaa.bbb.ccc.ddd	64
NM	Network mask	aaa.bbb.ccc.ddd	64
NG	Default gateway address	aaa.bbb.ccc.ddd	64
NR	Motion detection: No-motion Range	0...65535 d	43
NT	Motion detection: No-motion Time Period	0...65535 ms	43
OF	Output Format of Data String GL and GW	0...3	48
OM	Output Mask – to control hy host	0000...0111	51
OP	Open Device	0...255	54
PF	Pre Filter ON/OFF	0 or 1	44
PI	Download a saved image file to the DAD143.x's EEPROM	Image data string	57
P'n'	Polarity of Setpoint 'n', n= 0, 1 or 2: On / Off	0 or 1	53
PS	Protocol select: 1 ProfiNet, 2 Ethernet/IP, 3 EtherCAT, 4 Modbus TCP	1, 2, 3 or 4	63
RM	Reset Peak (Maximum) Value	None	49
RS	Device information: Read serial number	None	37
RT	Scale function: Reset Tare and Switch to Gross Indication	None	46
RU	Restore User Setup	None	42
RZ	Scale function: Reset Zero Point	None	46
SA	Auto-transmit: Send Triggered Average Value automatically	None	50, 59
SD	Trigger function: Start Delay	0... 500 ms	57
SG	Auto-transmit: Send Gross Value continuously	None	49
SH	Auto-transmit: Send Hold Value	None	50
SM	Auto-transmit: Send Peak (Maximum) Value	None	50
SN	Auto-transmit: Send Net Value continuously	None	49
S'n'	Setup of Setpoints S0, S1 and S2	-999999...+999999	52
SO	Auto-transmit: Send Peak to Peak Value	None	50
SP	Set Preset Tare	000000	46
SR	Reset Firmware (Warm Start)	None	36
SS	Save the Setpoint Data (S'n', H'n', P'n', A'n') to the EEPROM	None	57
ST	Scale function: Set Tare and Switch to Net Indication	None	46
SU	Save User Setup	None	41
SV	Auto-transmit: Send Valley Value	None	50
SW	Auto-transmit: Send Data String „Net/Gross/Status“ continuously	None	50
SZ	Scale function: System Zero Point	None	45
TE	Trigger function: Trigger on Rising Edge (1) or Falling Edge (0)	0 or 1	58
TH	Trigger Hold (save the actual weight/reading)		49
TI	Trigger function: Averaging Time for Automatic Taring	0...65535 ms	47
TL	Trigger function: Trigger Level	0...999999	58
TM	Tare Mode	0 ... 1	40
TN	Non Volatile Tare value ON/OFF @ power OFF	0 or 1	40
TR	Trigger function: Software Trigger	None	58
TW	Trigger function: Window for Automatic Taring	0...65535	46
UR	Update Rate (average of 2 exp. 'n' values – 2 exp 7 = 128)	0...7	45
WP	Save the Setup Data (FL, NR, NT, AD, BR, DX) to the EEPROM	None	56
ZI	Initial Zero Setting ON/OFF	0 or 1	40
ZM	Zero Mode	0 or 1	41
ZN	Non Volatile Zero Value ON/OFF @ power OFF	0 or 1	40
ZR	Calibration: Zero Range	0...999999	40
ZT	Zero Tracking – disable (0), enable (1 – legal for trade) or 2 ...255	0...255	39

8.1. Special Commands of DAD143.x – Overview

Command	Short description	Parameter value
	Commands For Application Filling (In / Out)	
	These commands are part of the manual “Dose In” & “Dose Out” and can be used for: FT1 - firmware type 1 (dose in) or FT3 - firmware type 3 (dose out).	
DI	Dose Info	For detailed information/description see separate manuals
SC	Start cycle	
AC	Abort cycle	
DT	Dose tare (only firmware type 1)	
PD1 to PD23	Parameters for filling in / filling out	
GD	Get dosed value	
SD	Save the filling parameters	

8.1.1. AT Auto Transmit (only for RS 232 connection)

The AT command parameters have the following meaning in the DAD 143.x, using serial port:

- 0: IDLE (OFF, Factory default)
- 1: GROSS
- 2: NET
- 3: AVERAGE
- 4: SAMPLE
- 5: LONG WEIGHT VALUE
- 6: PEAK
- 7: HOLD
- 8: VALLEY
- 9: PEAK TO PEAK
- 10: HBM AED

Note: Setting AT 10 will transmit the **net weight** in a format used by some devices of HBM. The format is:

- If the net weight is negative, then a '-' (minus) will be sent, else a ' ' (space) will be sent.
- The numerical value of the net weight will be sent as seven digits with leading zeros.
- If the parameter DP is set to zero then no decimal point will be sent. If DP is different from zero a decimal point will be inserted in the digit string but it will remain seven characters long.
- The transmission will be terminated with a CR command (0x0D).

8.1.2. AT Auto Transmit (for PLC connection)

The AT command parameters have the following meaning in the DAD 143.x, using the Ports 1 or Port 2:

The data selector for cyclic data transfer is coded as follows:

- 0: Gross weight
- 1: Net weight
- 2: Tare
- 3: Average weight
- 4: Dosed weight
- 5: Peak value
- 6: Hold value
- 7: Valley value
- 8: Peak to peak value

Any other value will set the output to 0.0

Note: Setting AT 1 will transmit e.g. the **net weight** in the format:

- If the net weight is negative, then a '-' (minus) will be sent, else a ' ' (space) will be sent.
- The numerical value of the net weight will be sent as seven digits with leading zeros.

- If the parameter DP is set to zero then no decimal point will be sent. If DP is different from zero a decimal point will be inserted in the digit string but it will remain seven characters long.
- The transmission will be terminated with a CR command (0x0D).

8.1.3. LE Last Error (cmd only for RS 232 connection)

The following list shows the codes and meaning of the last error occurred in the DAD143.x.

Code	Name	Description
0	NO_ERROR	No error
1	INDEX_DOES_NOT_EXIST	Protocol index does not exist.
2	SUBINDEX_DOES_NOT_EXIST	The the sub-index does not exist.
3	PARAMETER_OUT_OF_RANGE	The parameter setting is out of range.
4	CAL_LOCKED	The command cannot be executed because the TAC protection is ON.
5	COMMAND_NOT_ALLOWED	The command is not allowed / unknown.
6	READ_FROM_WRITE_ONLY_PARAMETER	Reading from a write only parameter.
7	WRITE_TO_READ_ONLY_PARAMETER	Write to a read only parameter.
8	SYNTAX_ERROR	Syntax error.
9	COMMAND_FAILED	Command failed.
10	ZEROING_DISABLED	The Zeroing function has been disabled.
11	OUT_OF_ZERO_RANGE	Zeroing this weight is not permitted.
12	INPUT_RANGE_EXCEEDED	The electrical weight input is outside the specifications for the device.
13	LOAD_CELL_CONNECTION_ERROR	The loadcell(s) electrical inputs is not making sense.
14	READING_NOT_STABLE	The reading of this parameter is not stable.
15	OUT_OF_TARE_RANGE	The requested Tare value is outside the allowed range.

Below you see two examples of occurred errors, using the command LE.

Master (PC / SPS) sends	Slave (DAD143.x) responds	Meaning (see above Error List)
LE↵	E:001	Code 1: Protocol index does not exist
LE↵	E:012	Code 12: electrical weight input is outside the specs, e.g. UNDER RANGE



Setup via PC / PLC - Command Descriptions

For better clarity, all commands are divided into groups as described on the following pages. Each command has to be completed with a CR (Enter), which is shown in the following tables as “↵”.

For each command, the Modbus Index / Sub-Index are displayed in brackets [Index 0xNNNN Sub 0xSS] and explained in the communication profile ‘Modbus TCP’. In case of no index mentioned, the command is not available for Modbus TCP.

8.2. System Diagnosis Commands – ID, IH, IV, IS, SR, RS

Use these commands you get the DAD143.x type, firmware version or device status. These commands are sent without parameters.

8.2.1. ID Get Device Identity

[Index 0x2900 Sub 0x08]

Master (PC / SPS) sends	Slave (DAD143.x) responds
ID↵	D:1430

The response to this request gives the actual identity of the active device. This is particularly useful when trying to identify different device types on a bus.

Note: The ID 1430 is valid for firmware type 0. All other ID's / Firmware-Types see command FT (page 41).

8.2.2. IV Get Firmware Version

[Index 0x2900 Sub 0x09]

Master (PC / SPS) sends	Slave (DAD143.x) responds
IV↵	V:0101

The response to this request gives the firmware version e.g. 1.0.1 of the active device.

8.2.3. IS Get Device Status

[Index 0x2900 Sub 0x0A]

Master (PC / SPS) sends	Slave (DAD143.x) responds
IS↵	S:067000 (example)

The response to this request comprises of two 3-digit decimal values (001 and 000), which is decoded according to the table below:

Leftmost 3-digit value		Rightmost 3-digit value	
1	Signal stable (no motion)	1	(not used)
2	Zeroing action performed	2	(not used)
4	Tare active	4	(not used)
8	(not used)	8	(not used)
16	Average data ready	16	(not used)
32	(Setpoint-) output 0 active	32	(not used)
64	(Setpoint-) output 1 active	64	(not used)
128	(Setpoint-) output 2 active	128	(not used)

The example decodes the result S: 067000 (binary 01000011) as follows:

- Signal stable (no motion) [$2^0 = 1$, LSB]
- Zeroing action performed [$2^1 = 2$]
- Tare not active [= 0]
- Output 0 active [= 0]
- Output 1 active [$2^6 = 64$]
- Output 2 not active [= 0]

Note: Not used bits are set to zero at the DAD143.x.

8.2.4. SR Reset DAD143.x Firmware

[Index 0x2007 Sub 0x04]

Master (PC / SPS) sends	Slave (DAD143.x) responds
SR↵	OK

This command will respond with ‘OK’ and after maximum 400 ms perform a complete reset of the DAD143.x. It has the same functionality as power OFF and ON again.

8.2.5. RS Read Serial Number

[\[Index 0x2900 Sub 0x0C\]](#)

Issuing the RS command will return the current serial number in the format S+12345678.

Master (PC / SPS) sends	Slave (DAD143.x) responds	Meaning
RS↵	S+00298702	Serial Number: 0298702

8.3. Calibration Commands – CE, CM'n', CI, MR, DS, DP, CZ, CG, ZT, FD, ZR, ZI, AZ, AG, CS, SU, RU, FT

8.3.1. CE Read TAC* Counter / Open Calibration Sequence

[\[Index 0x2300 Sub 0x03\]](#)

With this command you can read the TAC counter (*TAC = Traceable Access Code) or you can open a calibration sequence.

Master (PC / SPS) sends	Slave (DAD143.x) responds	Meaning
CE↵	E+00017 (example)	Request: TAC counter CE17
CE 17↵	OK	Calibration sequence active

This command must be issued PRIOR to any attempt to set the calibration parameters AG, AZ, CM, CI, DS, DP, CZ, CG, ZT, ZR, FD or CS. In legal for trade applications the TAC counter can be used to check if critical parameters have been changed without re-verification. After each calibration the TAC counter increases by +1.

Example 'Enable Calibration Sequence': Setup of 'zero point', 'system gain' and 'decimal point position'.

The chosen calibration weight has the value 5000 (increments). That could be 500 g, 5 kg or 5000 kg. We calibrate with 500 g. The decimal point is set up by command DPx (x = 1, 2 or 3), here 1 figure after the decimal point. A measured weight of 500 g is displayed as 500.0 g.

Master (PC / SPS) sends	Slave (DAD143.x) responds	Meaning
CE↵	E+000017 (example)	Read TAC counter value 17
Adjust zero: The scale has to be empty. No load applied!		
CE17↵	OK	Enable Calibration sequence
CZ↵	OK	System/Scale zero point saved
Adjust gain: First put the calibration weight on the scale (here 500 g)!		
CE17↵	OK	Enable Calibration sequence
CG5000↵	OK	Setting the span
CG↵	G+05000	Request: span setting 5000 d
Decimal Point: Set one decimal		
CE17↵	OK	Enable Calibration sequence
DP1↵	OK	Setting: decimal point to 0000.0
Store Calibration non volatile		
CE17↵	OK	Enable Calibration sequence
CS↵	OK	Save calibration data in EEPROM
Check new TAC counter value		
CE↵	E+000018	Read new TAC counter value 18

Zero point, gain and decimal point position were saved in the EEPROM; the calibration counter (TAC) is increased automatically by +1.

8.3.2. CM'n' Set Maximum Output Value

[\[CM1: Index 0x2300 Sub 0x07\]](#)

[\[CM2: Sub 0x0E\]](#)

[\[CM3: Sub 0x0F\]](#)

This command (CM'n' with n = 1, 2 or 3) is used to set up the maximum output value (respective the switching point in multi range applications). Permitted values are from 1 to 999 999.

Master (PC / SPS) sends	Slave (DAD143.x) responds	Meaning
CM↵	M+050000	Request: CM = 50000 d
CE↵	E+00017 (example)	Request: TAC counter CE17
CE 17↵	OK	Calibration sequence active
CM 30000↵	OK	Setup: CM = 30000 d

This value will determine the point at which the output will change to “00000”, signifying over-range respective the point at which the output will change the measuring range / interval size.

Application	CM 1 = MAX 1	CM 2 = MAX 2	CM 3 = MAX 3
Single range	CM 1 = 1...999 999	CM 2 = 0 (means CM 2 not used)	CM 3 = 0 (means CM 3 not used)
Dual range or dual interval (→ Command MR)	CM 1 = 1...MAX 1	CM 2 = MAX 1...999 999	
Triple range or triple interval Teilungen (→ Befehl MR)	CM 1 = 1...MAX 1	CM 2 = MAX 1...MAX 2	CM 3 = MAX 2...999 999

It is necessary: MAX 1 < MAX 2 < MAX 3

Note: The range, in which a scale can be set to zero (SZ) or automatic zero tracking (ZT) is active, is +/- 2% of CM value. But for none legal for trade applications you can change the behaviour with the settings of ZT (see 10.2.8) and/or ZR (see 10.2.10).

Factory default: CM1 = 999 999, CM 2 = 0, CM 3 = 0

8.3.3. CI Set Minimum Output Value

[Index 0x2300 Sub 0x08]

This command is used to set up the minimum output value. Permitted values are from – 999 999 to 0.

Master (PC / SPS) sends	Slave (DAD143.x) responds	Meaning
CI↵	I-010009	Request: CI = –10009 d
CE↵	E+00017 (example)	Request: TAC counter CE17
CE 17↵	OK	Calibration sequence active
CI –100↵	OK	Setup: CI = –100 d

This value will determine the point at which the output will change to “UUUUUUU”, signifying under-range.

Note: In bipolar applications (e.g. force- or torque measurements) this parameter defines the max. output value for input signals with negative sign.

Factory default: CI = –010009

8.3.4. MR Set Multi-range / Multi-interval

[Index 0x2300 Sub 0x0D]

This command is only relevant, if CM 2 > 0 or CM 3 > 0. In this case, this command defines, if the application is multi-range or multi-interval weighing. Permitted values are 0 (Multi-interval) or 1 (Multi-range).

Master (PC / SPS) sends	Slave (DAD143.x) responds	Meaning
MR↵	M+00000	Request: MR = 0 (Multi-interval)
CE↵	E+00017 (example)	Request: TAC counter CE17
CE 17↵	OK	Calibration sequence active
MR 1↵	OK	Setup: MR = 1 (Multi-range)

Note: Single range applications ignore this parameter.

8.3.5. DS Set Display Step Size

[Index 0x2300 Sub 0x0C]

This command allows the output to step up or down by a unit other than 1. Permitted values are 1, 2, 5, 10, 20, 50, 100, 200 and 500.

Master (PC / SPS) sends	Slave (DAD143.x) responds	Meaning
DS↵	S+00002	Request: Step size 2
CE↵	E+00017 (example)	Request: TAC counter CE17
CE 17↵	OK	Calibration sequence active
DS 50↵	OK	Setup: Step size 50

Legal for trade applications allow for up to 10000 intervals. The allowed step size has to be considered.

Factory default: DS = 00001

8.3.6. DP Set Decimal Point Position

[\[Index 0x2300 Sub 0x0B\]](#)

This command allows the decimal point to be positioned anywhere between leftmost and rightmost digits of the 5-digit output result. Permitted values are 0, 1, 2, 3, 4, 5. Position 0 means no decimal point.

Factory default: DP = 00000

Master (PC / SPS) sends	Slave (DAD143.x) responds	Meaning
DP↵	P+00003	Request: Position of decimal point 3
CE↵	E+00017 (example)	Request: TAC counter CE17
CE 17↵	OK	Calibration sequence active
DP 0↵	OK	Setup: no decimal point

8.3.7. CZ Set Calibration Zero Point

[\[Index 0x2300 Sub 0x0A\]](#)

This is the reference point for all weight calculations, and is subject to TAC control.

Factory default: approx. 0 mV/V input signal

Master (PC / SPS) sends	Slave (DAD143.x) responds	Meaning
CE↵	E+00017 (example)	Request: TAC counter CE17
CE 17↵	OK	Calibration sequence active
CZ 0↵	OK	Zero point saved

8.3.8. CG Set Calibration Gain (Span)

[\[Index 0x2300 Sub 0x04\]](#)

This is the reference point for calibration with load, and is subject to TAC control.

Permitted values are from 1 to 999 999.

Master (PC / SPS) sends	Slave (DAD143.x) responds	Meaning
CG↵	G+010000	Request: Calibration weight = 10000 d
CE↵	E+00017 (example)	Request: TAC counter CE17
CE 17↵	OK	Calibration sequence active
CG 15000↵	OK	Setup: Calibration weight = 15000 d

For calibrating an input signal near the display maximum (CM) will give the best system performance. The minimum calibration load of at least 20% is recommended. Is the calibration weight smaller than 1% of display maximum (CM), the DAD143.x will respond with an error message ("ERR").

Factory default: 10000 = 2.000 mV/V input signal

8.3.9. CV Calibrate Value

[\[Index 0x2300 Sub 0x18\]](#)

This is the number of increments for absolute calibration, and is subject to TAC control.

Master (PC / SPS) sends	Slave (DAD143.x) responds	Meaning
CV↵	G+100000	Cal. value is 10000 increments

8.3.10. AV Show Actual Internal mV/V Value

[\[Index 0x2900 Sub 0x12\]](#)

Master (PC / SPS) sends	Slave (DAD143.x) responds	Meaning
AV↵	A+02644	mV/V value is 0.2644 mV/V

Note: This value is for **ro** (read only). This means no TAC protection.

8.3.11. ZT Zero Tracking

[\[Index 0x2100 Sub 0x12\]](#)

This command enables / disables the zero tracking function. ZT = 0 disables the zero tracking, ZT = 1 or higher enables the zero tracking, independent of decimal point setting. Issuing the command without any parameter returns the current ZT value. Permitted values are 0 to 255.

Master (PC / SPS) sends	Slave (DAD143.x) responds	Meaning
ZT↵	Z:001	Request: ZT status
CE↵	E+00017 (example)	Request: TAC counter CE17
CE 17↵	OK	Calibration sequence active
ZT 0↵	OK	Setup: ZT = Disabled

ZT = enabled - performed only on results less than $\pm ZT$ range at a rate of 0.4d/sec.

ZT = 1 means $\pm 0.5d$

ZT = 100 means $\pm 50 d$

Factory default: ZT = 1 [Enabled]

8.3.12. FD Reset to Factory Default Settings

[\[Index 0x2006 Sub 0x02\]](#)

This command puts the DAD143.x back to a known state. The factory default settings data will be written to the EEPROM and the TAC value will be incremented by +1.

Note: All calibration and setup settings will be lost by issuing this command!

The user setup - stored via command SU – will not be overwritten and remains untouched.

Master (PC / SPS) sends	Slave (DAD143.x) responds	Meaning
CE↵	E+00017 (example)	Request: TAC counter CE17
CE 17↵	OK	Calibration sequence active
FD↵	OK	Factory default setting

8.3.13. ZR Zero Range

[\[Index 0x2300 Sub 0x11\]](#)

Sets the zero range manually – this is the range in divisions within which the weighing scale can be zeroed.

Issuing the ZR command without any parameter will return the current value.

Permitted values are 0 to 999 999. A value of zero 0 disables the zeroing of the scale.

Master (PC / SPS) sends	Slave (DAD143.x) responds	Meaning
ZR↵	R+002000	Request: ZR = 2000 d
CE↵	E+00017 (example)	Request: TAC counter CE17
CE 17↵	OK	Calibration sequence active
ZR 100↵	OK	Setup: Zero range = 100 d

Factory default: ZR = 0

8.3.14. ZI Initial Zero ON / OFF

[\[Index 0x2300 Sub 0x10\]](#)

Can proceed an initial ZERO @ power ON. Permitted values are 0 (OFF) or 1 (ON).

Master (PC / SPS) sends	Slave (DAD143.x) responds	Meaning
ZI↵	Z:001	Request: ZI = 1 (ON)
CE↵	E+00017 (example)	Request: TAC counter CE17
CE 17↵	OK	Calibration sequence active
ZI 0↵	OK	Setup: Initial Zero is OFF

Factory default: ZI = 0

8.3.15. TM Tare mode

[\[Index 0x2300 Sub 0x12\]](#)

This command sets the tare mode. Permitted values are 0 or 1.

Master (PC / SPS) sends	Slave (143.X) responds	Meaning
CE↵	E+00017 (example)	Request: TAC counter CE17
CE17↵	OK	Calibration sequence active
TM1↵	OK	Setup: Tare mode = 1

The tare modes are defined as:

- If TM = 0, then taring of negative values is allowed
- If TM = 1, then only positive values can be tared – use e.g. in approved applications.

8.3.16. TN Set / Clear Non-Volatile Tare

[\[Index 0x2300 Sub 0x13\]](#)

This command sets the tare mode to volatile or non-volatile. Value range is 0 or 1; Factory default is 0 (volatile). If set to 1 (non-volatile), every set/clear tare will write the value directly to the EEPROM.

Master (PC / SPS) sends	Slave (143.X) responds	Meaning
CE↵	E+00017 (example)	Request: TAC counter CE17
CE17↵	OK	Calibration sequence active
TN↵	T:000	Actual setting: TN = volatile
TN1	OK	Setup: TN = non-volatile

8.3.17. ZN Set / Clear Non-Volatile Zero

[\[Index 0x2300 Sub 0x14\]](#)

This command sets the zero mode to volatile or non-volatile. Value range is 0 or 1; Factory default is 0 (volatile). If set to 1 (non-volatile), every set/clear zero will write the value directly to the EEPROM.

Master (PC / SPS) sends	Slave (143.X) responds	Meaning
CE↵	E+00017 (example)	Request: TAC counter CE17
CE17↵	OK	Calibration sequence active
ZN↵	Z:000	Actual setting: ZN = volatile
ZN1	OK	Setup: ZN = non-volatile

8.3.18. ZM Zero Mode

[\[Index 0x2300 Sub 0x19\]](#)

This command sets the zero mode. Permitted values are 0 or 1.

Master (PC / SPS) sends	Slave (143.X) responds	Meaning
CE↵	E+00017 (example)	Request: TAC counter CE17
CE17↵	OK	Calibration sequence active
ZM1↵	OK	Setup: Zero mode = 1

The zero modes are defined as:

- If ZM = 0, then the automatic zeroing defined by the commands TW and TI will tare the scale.
- If ZM = 1, then the scale will be zeroed instead - in approved applications.

8.3.19. AZ Absolute zero point calibration (eCal)

[\[Index 0x2300 Sub 0x02\]](#)

The command AZ is used as reference point for all weight calculations and will setup in mV/V. Permitted values are $\pm 33\ 000$ ($= \pm 3.3000$ mV/V).

Master (PC / SPS) sends	Slave (DAD143.x) responds	Meaning
AZ↵	Z+0.2796	Request: Zero point @ 0.2796 mV/V
CE↵	E+00017 (example)	Request: TAC counter CE17
CE 17↵	OK	Calibration sequence active
AZ_00500↵	OK	New: Zero point @ 0.0500 mV/V

Factory default: 00000d @ 0.0000mV/V input signal.

8.3.20. AG Absolute gain calibration (eCal)

[\[Index 0x2300 Sub 0x01\]](#)

The command AG is used as absolute gain (or measuring range) for all weight calculations and will setup in mV/V. Permitted values are $\pm 33\ 000$ ($= \pm 3.3000$ mV/V).

Master (PC / SPS) sends	Slave (DAD143.x) responds	Meaning
AG↵	G+0.1868	Request: gain 10 000d @ 0.1868 mV/V
CE↵	E+00017 (example)	Request: TAC counter CE17
CE 17↵	OK	Calibration sequence active
AG_+011200_+005000↵	OK	New: gain 5 000d @ 1.12 mV/V

Factory default: 10 000d @ 2.0000mV/V input signal.

8.3.21. CS Save the Calibration Data

[\[Index 0x2004 Sub 0x02\]](#)

This command results in the calibration data being saved to the EEPROM and causes the TAC to be incremented by +1.

Master (PC / SPS) sends	Slave (DAD143.x) responds	Meaning
CE↵	E+00017 (example)	Request: TAC counter CE17
CE 17↵	OK	Calibration sequence active
CS↵	OK	Calibration values saved

The CS command saves all of the calibration group values, as set by AG, AZ, CZ, CG, CM, DS, DP and ZT. The command returns ERR and has no updating action unless it was preceded by the CE_XXXX.

8.3.22. SU Save User Setup in EEPROM

This command saves all the setup data including calibration non-volatile in EEPROM. In delivery status the user setup contains the factory default settings (as FD command).

Master (PC / SPS) sends	Slave (DAD143.x) responds	Meaning
CE↵	E+00017 (example)	Request: TAC counter CE17
CE 17↵	OK	Store sequence active
SU↵	OK	User setup stored in EEPROM

8.3.23. RU Restore User Setup to DAD143.x

This command restores the user setup including the calibration from the EEPROM, the TAC counter is increased by +1. To activate, the SR command (warm start) must be performed or just re-start the DAD 143.

Master (PC / SPS) sends	Slave (DAD143.x) responds	Meaning
CE↵	E+00017 (example)	Request: TAC counter CE17
CE 17↵	OK	Restore sequence active
RU↵	OK	Restore from EEPROM
SR↵	OK	Activate restored user setup

8.3.24. FT Firmware Type

[\[Index 0x2300 Sub 0x15\]](#)

The DAD143.x with firmware version 143.x81.v.1.01 or higher can be used to run different applications. The respective firmware type can be freely selected with the FT command.

The different firmware types of FT are:

FT = 0 is the basic version with checkweigher functions, content of this manual.

The device ID for this firmware type is **1430**.

FT = 1 is the version for optimized 'DOSE IN' of fluids, e.g. a weighing filler for bottles with coarse, medium and fine feed. The device ID for this firmware type is **1434**.

FT = 3 is the version for 'DOSE OUT' materials, e.g. into a keg or bag with coarse and fine feed.

The device ID for this firmware type is **1436**.

Factory default: FT=0.

Note:

Please note, the firmware type selection is locked in the same way as the calibration, that means it must be unlocked with the command "CE n" before the firmware type can be set. Then the FT setting must be saved with the command "CS".

8.4. Motion Detection Commands – NR, NT

The motion detection facility provides a means of disabling certain functions whenever a condition of instability, or “motion”, is detected. The “no-motion”, or “stable” condition is achieved whenever the signal is steady for the period of time set by NT, during which it cannot fluctuate by more than NR increments. The stable condition activates the relevant bit of responses to “Info Status” (IS).

Following functions are disabled if motion is detected: “Calibrate Zero” (CZ) “Calibrate Gain” (CG) “Set Zero” (SZ) and “Set Tare” (ST). After such a command the system returns an error (“ERR”), if the signal is not stable.

8.4.1. NR Set ‘No-motion’ Range

[\[Index 0x2100 Sub 0x0A\]](#)

This is the range within which the weighing signal is allowed to fluctuate and still be considered as “stable”. Permitted values are from 1 to 65535.

Master (PC / SPS) sends	Slave (DAD143.x) responds	Meaning
NR←	R+00010	Request: NR = 10 d
NR 2←	OK	Setup: NR = 2 d
WP←	OK	Setup saved

Example: For NR = 2 the fluctuations within a maximum of ± 2 d, in the period NT, will be considered “stable”.

Factory default: NR = 1 [= ± 1 d]

8.4.2. NT Set ‘No-motion’ Time Period

[\[Index 0x2100 Sub 0x0B\]](#)

This is the time period (in milliseconds) over which the weight signal is checked to see if it is “stable” or has “no-motion”. The weight signal has to vary by less than NR divisions over the time period NT to be considered ‘stable’.

Permitted values are from 1 to 65535.

Master (PC / SPS) sends	Slave (DAD143.x) responds	Meaning
NT←	T+01000	Request: NT = 1000 ms
NT 500←	OK	Setup: NT = 500 ms
WP←	OK	Setup saved

If the value of NT = 500 milliseconds, the output must not fluctuate more than NR increments within 500 milliseconds in order to be considered “stable”.

Factory default: NT = 1000 [ms]

8.5. Filter Setting Commands – FM, FL, PF, UR

A digital filter can be set which will eliminate most of the unwanted disturbances. The commands **FM** and **FL** are used to define the digital filter settings, the command **UR** is used to define an averaging of up to 128 measurement values. Please note that these filters are positioned immediately after the A/D Converter and therefore affect all aspects of the weighing operation.

8.5.1. FM Filter Mode

[\[Index 0x2100 Sub 0x09\]](#)

This command defines the filter mode. Choose the filter mode for your application.

Permitted values are “0” for IIR filter and “1” for FIR filter.

Master (PC / SPS) sends	Slave (DAD143.x) responds	Meaning
FM←	M+00000	Request: FM = 0 (IIR filter)
FM 0←	OK	Setup: FM = 0 (IIR filter)
WP←	OK	Setup saved

The digital IIR filter operates as 2nd order low pass filter and Gaussian characteristics. The attenuation is 40dB/decade (12 dB/octave).

The digital FIR filter works as a low-pass filter with quick response; damping see table mode 1.

Factory default: FM = 0 (IIR filter)

8.5.2. FL Filter Settings

[\[Index 0x2100 Sub 0x04\]](#)

This command defines the 3dB filter cut-off frequency.

Master (PC / SPS) sends	Slave (DAD143.x) responds	Meaning
FL↵	F+00003	Request: FL = 3 (4 Hz)
FL 7↵	OK	Setup: FL = 7 (0.5 Hz)
WP↵	OK	Setup saved

The permitted settings are from 0 and 8 (see below table).

Factory default: FL = 3.

Mode 0 (IIR filter) Settings / Characteristic

FL	Settling time to 0.1% (ms)	3dB Cut-off frequency (Hz)	Damping @300Hz (dB)	UR0 [= 1]	UR7 [= 128]
				Output-rate* (samples/s) --highest--	Output-rate* (samples/s) --lowest--
0	-	** (Pre-Fil)		600	4.69
1	55	18	57	600	4.69
2	122	8	78	600	4.69
3	242	4	96	600	4.69
4	322	3	104	600	4.69
5	482	2	114	600	4.69
6	963	1	132	600	4.69
7	1923	0.5	149	600	4.69
8	3847	0.25	164	600	4.69

* Output-rate = $600/2^{UR}$ samples/s

** Pre-filter 18 Hz @ 60 dB/dec

UR	0	1	2	3	4	5	6	7
Average of 2^{UR} values	1	2	4	8	16	32	64	128
Output rate (samples/s)	600	300	150	75	37.5	18.8	9.4	4.69

** **Note:** The pre-filter can be switched ON and OFF with the command **PF** – settings are 0 (OFF) or 1 (ON).
 - This feature can be used with ASCII communication or Modbus TCP [\[Index 0x2100 Sub 0x16\]](#).
 - The use is for specialists only.

Please Note: The DAD 143.x output rate is a function of the settings FM – FL – UR !

Mode 1 (FIR filter) Settings / Characteristic

FL	Settling time to 0.1%	3 dB Cut-off frequency	20 dB damping at frequency	40 dB damping at frequency	Damping in the stopband	Stop band	UR0 [= 1]	UR7 [= 128]
	(ms)	(Hz)	(Hz)	(Hz)	(dB)	(Hz)	Output rate * --highest-- (samples/s)	Output rate * --lowest-- (samples/s)
0	No filtering	** (Pre-fil)					600	4.69
1	47	19.7	48	64	>90	>80	600	4.69
2	93	9.8	24	32	>90	>40	300	2.34
3	140	6.5	16	21	>90	>26	200	1.56
4	187	4.9	12	16	>90	>20	150	1.17
5	233	3.9	10	13	>90	>16	120	0.94
6	280	3.2	8	11	>90	>13	100	0.78
7	327	2.8	7	9	>90	>11	85.7	0.67
8	373	2.5	6	8	>90	>10	75	0.59

* Output-rate = $600/2^{UR}$ samples/s

** Pre-filter 18 Hz @ 60 dB/dec

UR	0	1	2	3	4	5	6	7
Average of 2^{UR} values	1	2	4	8	16	32	64	128
Output rate @ FL0 (samples/s)	600	300	150	75	37.5	18.8	9.4	4.69
Output rate @ FL1 (samples/s)	600	300	150	75	37.5	18.8	9.4	4.69
Output rate @ FL2 (samples/s)	300	150	75	37.5	18.8	9.4	4.7	2.34
Output rate @ FL3 (samples/s)	200	100	50	25	12.5	6.3	3.1	1.56
Output rate @ FL4 (samples/s)	150	75	37.5	18.8	9.4	4.7	2.3	1.17
Output rate @ FL5 (samples/s)	120	60	30	15	7.5	3.8	1.9	0.94
Output rate @ FL6 (samples/s)	100	50	25	12.5	6.3	3.1	1.6	0.78
Output rate @ FL7 (samples/s)	85.7	42.9	21.4	10.7	5.4	2.7	1.3	0.67
Output rate @ FL8 (samples/s)	75	37.5	18.8	9.4	4.7	2.3	1.2	0.59

Attention: In mode 1, the output rate is dependant on the selected filter level (FL) and will be automatically adjusted by the DAD143.x.

8.5.3. PF Pre-filter

[\[Index 0x2100 Sub 0x16\]](#)

Use of the Pre-filter command is recommended for experts only, get status or set.

Note: Special command for internal use of manufacturer or for specialists only. For use, please ask Hauch & Bach ApS or your supplier.

8.5.4. UR Update Rate and Averaging

[\[Index 0x2100 Sub 0x11\]](#)

Depending on the selected filter mode this command defines an averaging for the output value. The permitted settings are from 0 to 7 (see table below). The average value will always be calculated from 2^{UR} measurement values.

DAD143.x allows for the following settings:

UR	0	1	2	3	4	5	6	7
Average of 2^{UR} values	1	2	4	8	16	32	64	128

Check / Setup of the averaging:

Master (PC / SPS) sends	Slave (DAD143.x) responds	Meaning
UR↵	U+00003	Request: Averaging of 8 values
UR 7↵	OK	Setup: Averaging of 128 values
WP↵	OK	Setup saved

Factory default: 0 (no averaging, means 600 samples/sec)

8.6. Taring and Zeroing Commands – SZ, RZ, ZN, ST, RT, SP, TN, RW, TI

The following commands allow you to set and reset the zero and tare values. The zero set up during calibration remains the 'true zero' but the new 'current zero' can be set up by using the SZ command. If the SZ command is issued and accepted then all weight values will then be based on the new 'current zero'. Please remember that the zero value will be subject to the Zero tracking function if enabled. If the weight signal is not stable (as defined by the 'No motion' range NR and the 'No motion' time NT) then both, the set zero SZ and set tare ST commands, will be disabled.

See chapter 11 - Use in "Approved" applications.

8.6.1. SZ Set System Zero

[\[... see chapter 14.2.7\]](#)

This command sets a new "current zero" which is then the basis of all weight values until further updated by the zero tracking function, another SZ command or the "reset zero" command RZ.

Master (PC / SPS) sends	Slave (DAD143.x) responds	Meaning
SZ↵	OK	Set zero performed

The SZ command will fail (DAD143.x responds with ERR) if the new "current zero" is outside the active +/- zero range set with the ZR command. The SZ command will also fail if the weight signal is not stable as defined by the No motion range (NR) and the No motion time (NT). If the weight signal is "stable", the response to the IS command (Device Status) will show the "signal stable" bit active and the SZ command will be accepted (OK). If the "signal stable" bit is not active, the SZ command will be rejected and the DAD143.x will respond with ERR (error).

8.6.2. RZ Reset Zero

[\[... see chapter 14.2.7\]](#)

This command cancels the SZ command and the zero reading reverts to that set by the CZ command during calibration.

Master (PC / SPS) sends	Slave (DAD143.x) responds	Meaning
RZ↵	OK	Zero point CZ active

The DAD143.x responds to the RZ command with either OK or ERR. If OK is returned then the "zero action performed" bit in the Device Status (IS) response will be set to "0".

8.6.3. ST Set Tare

[... see chapter 14.2.7]

This command will activate the net weighing function by storing the current weight value as a tare value. The weight signal must be "stable" within the limits set by NR (No Motion Range) and NT (No Motion Time) commands for the "signal stable" bit to be active and set tare command to be accepted.

Master (PC / SPS) sends	Slave (DAD143.x) responds	Meaning
ST↵	OK	Tare performed / Net operation

If the weight signal is "stable", the response to the IS command (Device Status) will show the "signal stable" bit active and the ST command will be accepted (OK). If the "signal stable" bit is not active, the ST command will be rejected and the DAD143.x will respond with ERR (error).

8.6.4. RT Reset Tare

[... see chapter 14.2.7]

This command resets the tare and the weighing signal returns to gross mode.

Master (PC / SPS) sends	Slave (DAD143.x) responds	Meaning
RT↵	OK	Tare de-activated / Gross operation

The DAD143.x responds to the RT command with either OK or ERR. If OK is returned then the "tare active" bit in the Device Status (IS) response will be set to "0".

8.6.5. SP Set Preset Tare

[Index 0x2100 Sub 0x17]

This command sets a preset tare value.

Master (PC / SPS) sends	Slave (143.X) responds	Meaning
SP↵	T+000000	Tare value 0 (factory default)
SP1000	OK	Setup tare value 1000d

8.6.6. TW Window for Automatic Taring

[Index 0x2500 Sub 0x06]

This command defines an amplitude window for the automatic taring. The setting TW = 100 means, that the system calculates a new tare value, if the averaged net value of the empty scale falls within 100 digits of the net zero point. The new tare value will be averaged over the time period TI (see below). If the averaged tare value falls outside this window, then the tare value will not be updated.

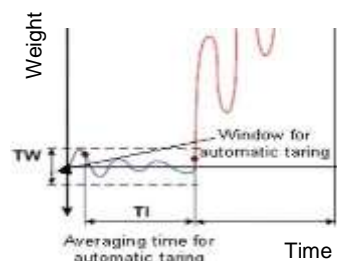

Permitted values are from 0 to 65535.

Default setting: TW = 0 [= automatic taring disabled]

Master (PC / SPS) sends	Slave (DAD143.x) responds	Meaning
TW↵	W+00000	Request: TW = 0 d
TW 100↵	OK	Setup: TW = 100 d

8.6.7. TI Averaging Time for Automatic Taring

[Index 0x2500 Sub 0x07]

This command defines the averaging time for the automatic taring. Within this time period the system calculates an averaged tare value.

Permitted values are from 0 to 65535.

Default setting: TI = 0 ms [= automatic taring disabled]

Master (PC / SPS) sends	Slave (DAD143.x) responds	Meaning
TI↵	T+00000	Request: TI = 0 ms
TI 200↵	OK	Setup: TI = 200 ms

 Remark to TW / TI:

The dynamic automatic taring (virtually) will be proceeded only in case both commands are setup with permitted values. In the case, one of both is set to “0”, the automatic taring is switched off.

8.7. Output Commands – GG, GN, ON, GT, GS, GW, GA, GH, GM, RM, GO, GV

The following commands “Get’s” the gross, net, tare, ADC sample values etc. from the DAD143.x.

8.7.1. GG Get Gross Value

[Index 0x2000 or 0x2001 / Sub 0x01] or [Index 0x2900 Sub 0x01]

Master (PC / SPS) sends	Slave (DAD143.x) responds	Meaning
GG↵	G+001.100	Gross value: 1.100 d

8.7.2. GN Get Net Value

[Index 0x2000 or 0x2001 /Sub 0x02] or [Index 0x2900 Sub 0x02]

Master (PC / SPS) sends	Slave (DAD143.x) responds	Meaning
GN↵	N+001.000	Net value: 1.000 d

8.7.3. GT Get Tare Value

[Index 0x2000 or 0x2001 / Sub 0x03] or [Index 0x2900 Sub 0x03]

Master (PC / SPS) sends	Slave (DAD143.x) responds	Meaning
GT↵	T+000.100	Tare value: 100 d

8.7.4. GS Get ADC Sample Value

[Index 0x2900 Sub 0x07]

This command gets the actual Analogue to Digital Converter (ADC) value. This can be useful during development or when calibrating to see how much of the ADC range is being used.

Master (PC / SPS) sends	Slave (DAD143.x) responds	Meaning
GS↵	S+125785	ADC sample value = 125785 d

For service purposes it may be helpful to note the GS values for the “no-load” or “zero” output and when the “calibration load” is applied.

8.7.5. GW Get Data String “Net, Gross and Status“

Note: This command is only relevant for the serial interface RS 232.

Issuing the GW command, which has no parameters, will return the net weight, the gross weight, the status and the checksum values, all combined into one single string in the format **W+000100+00110001AF**. The first two sections of the return string comprise the net weight and gross weight results, followed by two hexadecimal characters, which represent two bitmapped status indicators. The last two hexadecimal characters represent the checksum, which is the inverse of the sum of all the ASCII values of the string, not including the checksum characters.

W	+000100	+001100	0	1	AF
Leading character signifies the GW	Net weight excluding decimal point	Gross weight excluding decimal point	First bitmapped binary value	Second bitmapped binary value	Checksum

The bitmapped characters are:

First bitmapped value	description	Second bitmapped value	description
1	Not used	1	No motion
2	Output 0 active	2	Zero action performed
4	Output 1 active	4	Tare active
8	Output 2 active	8	Not used

The checksum is derived as follows:

- Add the ASCII values (in hex) of all 17 characters in the string (result in hex is 351)
- Take the last two numbers (in hex 51)
- Invert the sign (result is FFFFFFFFAF)
- Use only the last two characters (AF)
- Checksum is AF

8.7.6. OF Output Format for Data String GW

Note: This command is only relevant for the serial interface RS 232.

This command puts the range information and/or the decimal point into the “long” data strings of the GW and GL output response.

Master (PC / SPS) sends	Slave (DAD143.x) responds	Meaning
CE↵	E+00017 (example)	Request: TAC counter CE17
CE17↵	OK	Calibration sequence active
OF1↵	OK	Setup: OF = 1

Output Format		
Parameter setting	Range Information	Decimal Point in GW response
0 (= factory default)	No	No
1	Yes	No
2	No	Yes
3	Yes	Yes

When the range information is selected, the data strings will change from G+000000 to Gn+000000, where $1 \leq n \leq 3$.

8.7.7. GA Get Triggered Average Value

[\[Index 0x2000 or 0x2001 / Sub 0x06\]](#) and [\[Index 0x2900 Sub 0x06\]](#)

This command reads the measurement result of a measurement cycle. The measurement value has been averaged according the defined measuring time. The trigger commands can be found in chapter 10.13.

Master (PC / SPS) sends	Slave (DAD143.x) responds	Meaning
GA↵	A+001.100	Request: GA = 1100 g

Note: For preventing errors during the read out of the data the register GA has stored the value 99999 at the beginning of the measurement cycle. The measurement result can only be read after the defined measuring time MT has been elapsed and before a new measurement cycle has been started.

8.7.8. GH Get Hold Value

[\[Index 0x2900 Sub 0x0F\]](#)

Get the actual weight value, activated by the logic inputs.

Master (PC / SPS) sends	Slave (DAD143.x) responds	Meaning
GH↵	H+001.800	Hold value: 1800 d

8.7.9. TH Trigger Hold Value

[\[... see chapter 14.2.7\]](#)

Saves the weight value of the last GH reading.

Master (PC / SPS) sends	Slave (DAD143.x) responds	Meaning
TH [↓]	OK	Save actual weight value

8.7.10. GM Get Peak Value

[\[Index 0x2900 Sub 0x0E\]](#)

The peak value is the maximum input value while your measurement.

Master (PC / SPS) sends	Slave (DAD143.x) responds	Meaning
GM [↓]	M+051.100	Peak value: 51100 d

8.7.11. RM Reset of Peak Value

[\[... see chapter 14.2.7\]](#)

Resets the peak value.

Master (PC / SPS) sends	Slave (DAD143.x) responds	Meaning
RM [↓]	OK	Reset Peak value

8.7.12. GO Get Peak To Peak Value

[\[Index 0x2900 Sub 0x11\]](#)

The peak to peak value is the difference value between the maximum and minimum input values while your measurement.

Master (PC / SPS) sends	Slave (DAD143.x) responds	Meaning
GO [↓]	O+091.100	Peak to Peak value: 91100 d

8.7.13. GV Get Valley Value

[\[Index 0x2900 Sub 0x10\]](#)

The valley value is the minimum input value while your measurement.

Master (PC / SPS) sends	Slave (DAD143.x) responds	Meaning
GV [↓]	V+000.100	Valley value: 100 d

8.8. Auto-Transmit Commands – SG, SN, SW, SA, SH, SM, SO, SV

Note: These commands can be used for serial port RS 232, only.

The following commands allow the gross weight or net weight values to be continuously sent. Continuous transmission starts as soon as the relevant command has been issued and finishes when any other valid command is accepted by the DAD143.x. The data output rate will depend on the baud rate being used e.g. with a baud rate of 115200 approximately 1000 values per second can be transmitted. The output rate of DAD143.x is max. 600 measurement values per second.

The continuous transmission of either the gross or net values will stop when another valid command is received.

8.8.1. SG Send Gross Value continuously

Master (PC / SPS) sends	Slave (DAD143.x) responds	Meaning
SG [↓]	G+001.100	Gross value: 1,100 d

8.8.2. SN Send Net Value continuously

Master (PC / SPS) sends	Slave (DAD143.x) responds	Meaning
SN [↓]	N+001.000	Net value: 1,000 d

8.8.3. SW Send Data String “Net, Gross and Status“ continuously

Issuing the SW command, which has no parameters, will return continuously the net weight, the gross weight, the status and the checksum values, all combined into one single string in the format **W+000100+001100010F**.

For more detailed information of the data string see command GW (chapter 8.8.5).

8.8.4. SA Send Triggered Average Value automatically

Master (PC / SPS) sends	Slave (DAD143.x) responds	Meaning
SA↵	OK	Auto-Transmit: triggered average value

This command will start to auto-transmit the measurement value of the current trigger cycle. The trigger setup commands are described in chapter 8.15.

8.8.5. SH Send Hold Value continuously

Master (PC / SPS) sends	Slave (DAD143.x) responds	Meaning
SH↵	H+001.100	Hold value: 1,100 d

8.8.6. SM Send Peak Value continuously

Master (PC / SPS) sends	Slave (DAD143.x) responds	Meaning
SM↵	M+001.100	Peak value: 1,100 d

8.8.7. SO Send Peak To Peak Value continuously

Master (PC / SPS) sends	Slave (DAD143.x) responds	Meaning
SO↵	O+001.100	Peak to Peak value: 1,100 d

8.8.8. SV Send Valley Value continuously

Master (PC / SPS) sends	Slave (DAD143.x) responds	Meaning
SV↵	V+000.100	Valley value: 100 d

8.9. Logic Input Functions & Status – AI’n’, IN

8.9.1. AI Assign input ‘n’

[\[Index 0x2D00 Sub 0x01 / 0x02\]](#)

This command reads / setup the function of the logical inputs. The values for ‘n’ are 0 or 1.

Master (PC / SPS) sends	Slave (DAD143.x) responds	Meaning
AI_1↵	I1:+00000	Reading Input 1: no function
AI_1_10↵	OK	Setup accepted
AI_1↵	I1:+00010	Input 1: display set to ‘Peak to Peak’ value

The 2 logic inputs ‘n’ can be used for the different functions:

- 00 - Input "n" has **no function**
- 01 - Input "n" acts as **Zero** button
- 02 - Input "n" acts as **Tare** button
- 03 - Input "n" acts as **Up arrow** button
- 04 - Input "n" acts as **Down arrow** button
- 05 - Input "n" starts the **Trigger** function
- 06 - Input "n" displays the **Average** value
- 07 - Input "n" displays the **Peak** value (maximum)
- 08 - Input "n" deletes the **Peak** value (maximum)
- 09 - Input "n" displays the **Hold** value
- 10 - Input "n" displays the **Peak to Peak** value
- 11 - Input "n" displays the **Valley** value (minimum)

- 12 - Input "n" disables the **buttons**
- 13 - Input "n" stores the **actual weight (Hold value)**
- 14 - Input "n" **tares the displays** and deletes all other values
- 15 - Input "n" **turn off display**

8.9.2. IN Read status of the logic inputs

[Index 0x2100 Sub 0x07]

This command reads the status of the digital inputs.

Master (PC / SPS) sends	Slave (DAD143.x) responds	Meaning
IN↵	I:0000	Reading: Input 0 or 1 inactive
IN↵	I:0001	Reading: Input 0 active
IN↵	I:0010	Reading: Input 1 active
IN↵	I:0011	Reading: Input 0 and 1 active

The status response is in the form of a four digit code where 0 = false and 1 = true (inputs are active 'high'). The least significant bit corresponding to Input 0.

8.10. Logic Output Commands - IO, OM, S'n', H'n', P'n', A'n', HT

The definitions for this section may be changed due to the fact that the definitions of the logic outputs for the DAD143.x, where the status depends on the weight value (setpoint) are to be defined. Each logic output can be assigned an independent setpoint value (S'n') with a corresponding hysteresis/polarity action (H'n', P'n') and allocation (A'n' – switch on the gross, net, peak, average etc. weight).

8.10.1. IO Read / Modify the Status of the logic Outputs

[Index 0x2100 Sub 0x06]

This command reads and can modify the status of the logic outputs (if enabled by the **OM** command). The status response is in the form of a four digit code where 0 = false and 1 = true (outputs are normally open, open drain MOSFETs), the least significant bit corresponding to Output 0 etc.

Master (PC / SPS) sends	Slave (DAD143.x) responds	Meaning
IO↵	IO:0001	Output 0 is high
IO↵	IO:0101	Outputs 0 and 2 are high
IO↵	IO:0111	Outputs 0, 1 and 2 are high

The status of the outputs can be changed by issuing the IO command with the appropriate 4 digit code e.g. IO 0001 where in this example output 0 will be activated (FET conducting). Please note that the status of the logic outputs is normally determined by the internal setpoints (see section 10.9.2) and therefore setting the logic output status using the IO commands is **not** allowed.

Setting

Master (PC / SPS) sends	Slave (DAD143.x) responds	Meaning
IO_010↵	OK	Setup output 1 is high
IO_011↵	OK	Setup outputs 0 and 1 are high
IO_111↵	OK	Setup outputs 0, 1 and 2 are high

However, the OM command can be used to allow the status of the logic outputs to be set via the IO command or set their status directly by the host application.

Factory default: IO=0000

8.10.2. OM Control of the logic outputs by the host application

[Index 0x2100 Sub 0x0C]

The logic outputs can be controlled by the host application (as opposed to the normal internal setpoints) if they are enabled by the OM command and the appropriate 4 digit code.

Master (PC / SPS) sends	Slave (DAD143.x) responds	Meaning
OM↵	OM:0001	Enable Output 0
OM↵	OM:0101	Enable Outputs 0 and 2
OM↵	OM:0111	Enable Outputs 0, 1 and 2

A “1” bit in the code enables the corresponding logic output to be controlled by the host application using the IO command. A “0” in the code leaves the corresponding logic output controlled by the internal setpoint. Logic output 0 is again the least significant bit.

Setting

Master (PC / SPS) sends	Slave (DAD143.x) responds	Meaning
OM_010←	OK	Enables output 1
OM_011←	OK	Enables outputs 0 and 1
OM_111←	OK	Enables outputs 0, 1 and 2

Note: When reading the status of the logic outputs using the IO command, the setpoint status will be returned regardless of the OM setting. Sending OM_0000 disables the external logic output control.

Factory default: OM=0000

8.10.3. A’n’ Assign action for setpoint ‘n’

[\[Index 0x2800 Sub 0x01 / 0x02 / 0x03\]](#)

This command is used to release the external control of the logic outputs: read or setup

Master (PC / SPS) sends	Slave (DAD143.x) responds	Meaning
A1←	A1:+00000	Output 1 based to gross value
A2←	A2:+00002	Output 2 based to peak value
A1_1←	OK	Output 1 set to base net value
A1←	A1:+00001	Output 1 based to net value

Choose the source for the output ‘n’ like follows:

- 00 - **Gross** value
- 01 - **Net** value
- 02 - **Peak** value (Maximum)
- 03 - **Average** value (check weigher)
- 04 - **Hold** value
- 05 - **Peak to Peak** value
- 06 - **Valley** value (Minimum)
- 07 - **Error 4 or 5**

8.10.4. S’n’ Setpoint Value

[\[Index 0x2600 Sub 0x01 / 0x02 / 0x03\]](#)

This command is used to read or setup the 3 setpoints S0, S1 and S2. Permitted value range is +/- 999 999.

Master (PC / SPS) sends	Slave (DAD143.x) responds	Meaning
S1←	S1:+001500	Request: Setpoint S1 = 1500 d
S1 3000←	OK	Setup: Setpoint S1 = 3000 d

Factory defaults: S’0’ = 1000 d , S’1’ = 5000 d, S’2’ = 9999 d

8.10.5. H’n’ Setpoint Hysteresis and Switching Action

[\[Index 0x2700 Sub 0x01 / 0x02 / 0x03\]](#)

The switching logic will be defined by the numeric value of hysteresis and the polarity.

The outputs can operate as “normally closed” or “normally open”, depending of the settings H’n’ and P’n’.

... continued next page

Examples of the swichting actions for a Setpoint value of 2 000kg

Polarity = 0 [OFF]:

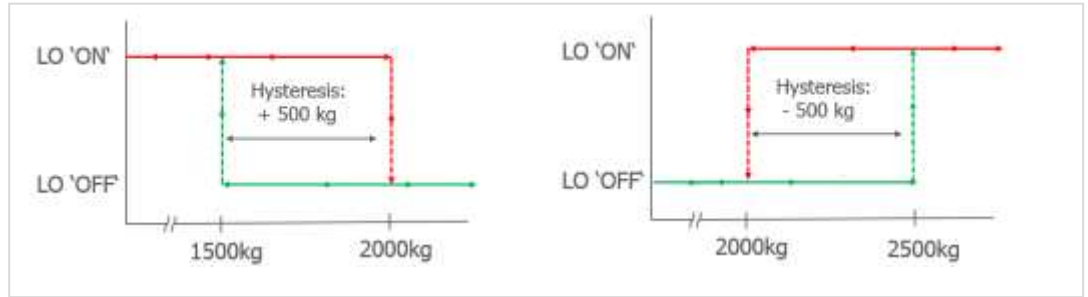

Polarity = 1 [ON]:

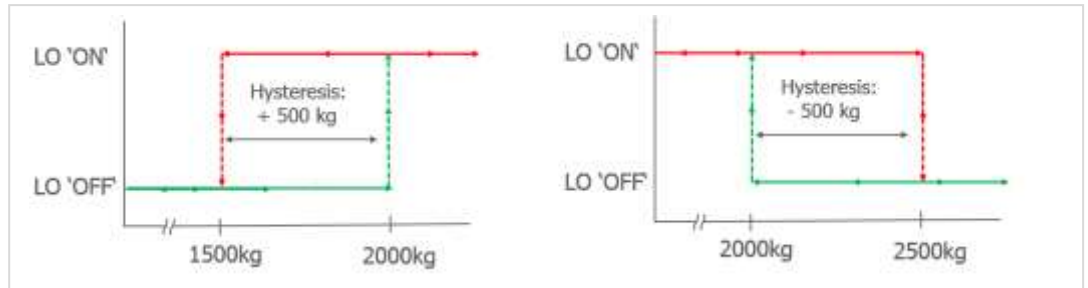

Master (PC / SPS) sends	Slave (DAD143.x) responds	Meaning
H1↵	H1:+00000	Request: hysteresis setpoint S1
H1_100↵	OK	Setup: hysteresis setpoint S1 to 100 d

Allowed hysteresis values are within the range from -32 768 to +32 767 at a step size of 1.

8.10.6. P'n' Polarity of Setpoint

[\[Index 0x2680 Sub 0x01 / 0x02 / 0x03\]](#)

This command is used to setup the switch characteristic of the 3 setpoints S0, S1 and S2.

Master (PC / SPS) sends	Slave (DAD143.x) responds	Meaning
P0↵	P0:+00000	Request: Polarity of setpoint S0 is OFF
P0_1↵	OK	Setup: Polarity of setpoint S0 is ON
P1_1↵	OK	Setup: Polarity of setpoint S1 is ON
P1↵	P:+00001	Request: Polarity of setpoint S1 is ON

Permitted values are 0 [OFF] and 1 [ON]

For further informations or better understanding, see the examples in chapter 10.9.5, too.

Note: All changes to the setpoint settings have to be stored in the EEPROM using the SS command.
See chapter 8.14.3.

8.10.7. HT Hold time for all Setpoints

[\[Index 0x2500 Sub 0x05\]](#)

This command defines the hold time for the setpoint limit. The signal has to exceed the setpoint limit continuously at least for this time period before a switch event will be initiated.

Note: This setup is valid for **all** 3 Logic Outputs.

Permitted value range is 0 to 65 535 ms.

Default setting: HT = 0 ms.

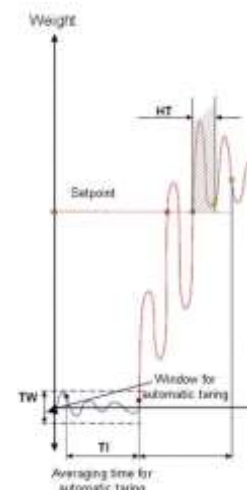

Master (PC / SPS) sends	Slave (DAD143.x) responds	Meaning
HT↵	H+00000	Request: HT = 0 ms
HT 200↵	OK	Setup: HT = 200 ms

8.11. Communication Setup Commands – AD, BR, DX, OP, CL, TD

8.11.1. AD Device Address

This command can set up the device address in the value range from 0 to 255.

Master (PC / SPS) sends	Slave (DAD143.x) responds	Meaning
AD↵	A:000	Request: Address 0 (= factory default)
AD_49↵	OK	Setup: Address 49

Setting the device address to “0” will cause the device to be permanently active, listening and responding to every command on the bus without the need for an OP command.

Note: After editing the address you first have to save the changes (command WP) and then restart the device.

8.11.2. BR Baud Rate

With this command the following baud rates can be setup: 9600, 19200, 38400, 57600, 115200, 230400 and 460800 Baud.

Master (PC / SPS) sends	Slave (DAD143.x) responds	Meaning
BR↵	B 115200	Request: 115200 Baud (= factory default)
BR_9600↵	OK	Setup: 9600 Baud

Factory default: 115200 baud

Note: After editing the baud rate you first have to save the changes (command WP) and re-start the device.

8.11.3. DX Operation Mode Half-/Full-Duplex

The DAD143.x can operate in half or full duplex mode.

Master (PC / SPS) sends	Slave (DAD143.x) resp.	Meaning
DX↵	X:001	Request: DX = 1 (full duplex, factory default))
DX 0↵	OK	Setup: DX = 0 (half duplex)

8.11.4. OP Open Device

This command, if sent without parameters, requests the address or device number of the device active on the bus. If sent with parameters, this enables the device defined by the parameters.

Master (PC / SPS) sends	Slave (DAD143.x) resp.	Meaning
OP↵	O:003	Request: Device #3 open
OP_14↵	OK	Setup: Open Device #14

8.11.5. CL Close Devices

This command will close DAD143.x device in a bus.

Master (PC / SPS) sends	Slave (DAD143.x) resp.	Meaning
CL↵	OK	Setup: All devices closed

8.12. Analog Output – AA, AH, AL, AM, AR (only DAD 143.1)

The following commands must be saved in EEPROM by command AS.

8.12.1. AA Analog Output Base

[\[Index 0x2100 Sub 0x01\]](#)

This command can setup the analog output base. Permitted values are 0 ... 9.

Master (PC / SPS) sends	Slave (DAD143.x) responds	Meaning
AA↵	A+00001	Request: base is gross value
AA_2↵	OK	Setup: base is Peak value

You can choose one out of the following analog output base:

- 0 - analog output follows **Gross** value (*GrO5*)
- 1 - analog output follows **Net** value (*nEt*)
- 2 - analog output follows **Peak** value (*PEA*)
- 3 - analog output follows **Average** value (*AUEr*)
- 4 - analog output follows **Hold** value (*HoLd*)
- 5 - analog output follows **Peak - Peak** value (*PP*)
- 6 - analog output follows **Valley** value (*VALL*)
- 7 - analog output follows **Display** value (*dISP*)
- 8 - analog output is switched **OFF** (*oFF*)
- 9 - analog output follows **Mass flow** value (*FLo* - firmware type 2 only)
- 10 - analog output follows **Analog Reference** value (*rEF*)

8.12.2. AH Set Analog High Level

[\[Index 0x2100 Sub 0x02\]](#)

Request / Set up high level for analog output. Permitted values are -999 999 ... +999 999d.

Master (PC / SPS) sends	Slave (DAD143.x) responds	Meaning
AH↵	H+010000	Request: setting 10 000 d
AH_30000↵	OK	Setup: 30 000 d

8.12.3. AL Set Analog Low Level

[\[Index 0x2100 Sub 0x03\]](#)

Request / Setup low level for analog output. Permitted values are -999 999 ... +999 999d.

Master (PC / SPS) sends	Slave (DAD143.x) responds	Meaning
AL↵	L+000000	Request: setting 0 d
AL_600↵	OK	Setup: 600 d

8.12.4. AM Set Analog Output Mode

[\[Index 0x2100 Sub 0x15\]](#)

Request / Setup mode for analog output. Permitted values are 0 ... 5.

Master (PC / SPS) sends	Slave (DAD143.x) responds	Meaning
AM↵	M:000	Request: setting 4 to 20mA
AM_3↵	OK	Setup: 0 to +10V

You can choose one out of the following analog output modes:

Mode	Output	Mode	Output
0	4 to 20mA	3	0 to +10V
1	0 to 20mA	4	-5 to +5V
2	0 to +5V	5	-10V to +10V

8.12.5. AR Set Analog Reference Value

[\[Index 0x2100 Sub 0x19\]](#)

Setup of a reference value for the analog output.

Permitted values are -999999 ... +999999, based on the cmd settings of **AL** and **AH**, see above.

8.13. Save Calibration and Setup – CS, WP, SS, AS, GI, PI

The calibration and setup parameters can be divided in 4 groups:

- **Calibration:** CM, DS, DP, CZ, CG, ZT, IZ and FD, etc. saved by command **CS**
- **Setup:** FL, FM, NR, NT, BR, AD, DX and others, saved by command **WP**
- **Setpoints:** S1, S2, S3, H1, H2, H3, A1, A2, A3 - saved by command **SS**
- **Analog outputs:** AA, AH, AL, AM - if available - saved by command **AS**

Note: Calibration data can only be saved if the TAC code is known and preceding the CS command. See the commands **CE** and **CS** in chapter 9.2.

The setup data and the setpoint data will be stored non-volatile in the EEPROM using the **WP** respective **SS** and **AS** command.

8.13.1. CS Save the Calibration Data

[\[Index 0x2004 Sub 0x02\]](#)

This command results in the calibration data being saved to the EEPROM and causes the TAC to be incremented by 1.

Master (PC / SPS) sends	Slave (DAD143.x) responds	Meaning
CE↵	E+00017 (example)	Request: TAC counter CE17
CE 17↵	OK	Calibration sequence active
CS↵	OK	Calibration values saved

The CS command saves all of the calibration group values, as set by AG, AZ, CZ, CG, CM, DS, DP, ZT etc. The command returns ERR and has no updating action unless it is preceded by the CE_XXXX.

8.13.2. WP Save the Setup Parameters

[\[Index 0x2004 Sub 0x03\]](#)

With this command the settings of the “Filter” (FL, FM), the “No-motion” (NR, NT), the “Inputs” (AI0, AI1) and the communication (AD, BR, DX) will be saved in the EEPROM.

Master (PC / SPS) sends	Slave (DAD143.x) responds	Meaning
WP↵	OK	Setup data saved
WP↵	ERR	Error

8.13.3. SS Save Setpoint Parameters

[\[Index 0x2004 Sub 0x05\]](#)

With this command the setpoints (S0, S1, S2), the setpoint hysteresis (H0, H1, H2) and the setpoint allocation (A0, A1, A2) will be saved in the EEPROM.

Master (PC / SPS) sends	Slave (DAD143.x) responds	Meaning
SS↵	OK	Setpoint parameters saved
SS↵	ERR	Error

8.13.4. AS Save Analog Output Parameters (only DAD 143.1)

[\[Index 0x2004 Sub 0x01\]](#)

With this command the action (AA), the analog low (AL), the analog high (AH) and the output mode (AM) will be saved in the EEPROM.

Master (PC / SPS) sends	Slave (DAD143.x) responds	Meaning
AS↵	OK	Analog output parameters saved
AS↵	ERR	Error

8.13.5. GI Get an Image File from the EEPROM

Retrieves a HEX-INTEL formatted EEPROM image file from the EEPROM of the source DAD143.x. The image file contains all stored information except the calibration data. This image file can be downloaded to any DAD143.x with the same firmware type and revision no. as the source DAD143.x.

8.13.6. PI Download an Image File to the EEPROM

Downloads a HEX-INTEL formatted EEPROM image file to the target DAD143.x EEPROM. The image file contains all stored information except the calibration data.

Attention: The target DAD143.x must have same firmware type and revision no. as the source DAD143.x.

8.14. Trigger Commands – SD, MT, GA, TE, TR, TL, SA

When using these commands, **e.g. a checkweigher** can be realized. The triggering of the measurement can be done by measuring signal, or by command TR or via a digital input. The time diagram of a typical checkweighing with explanations see next page.

Note: All changes to the trigger commands have to be stored in the EEPROM using the WP command. See chapter 8.14.2.

8.14.1. SD Start Delay Time

[\[Index 0x2100 Sub 0x0E\]](#)

This command defines a time delay between the trigger and the start of the measurement. Setting range: 0 ms to 500 ms.

Master (PC / SPS) sends	Slave (DAD143.x) responds	Meaning
SD↵	S+00100	Request: SD = 100 ms
SD 200↵	OK	Setup: SD = 200 ms

Default setting: SD = 0 ms; time plot of a typical checkweigher cycle see below

8.14.2. MT Measuring Time

[\[Index 0x2100 Sub 0x08\]](#)

This command defines the measuring time for the averaged measurement result. Setting range: 0 ms to 3000 ms.

Master (PC / SPS) sends	Slave (DAD143.x) responds	Meaning
MT↵	M+00100	Request: MT = 100 ms
MT 500↵	OK	Setup: MT = 500 ms

Note: The setting MT = 0 disables the trigger function and the averaging.

Default setting: MT = 0 [= trigger function disabled]; time plot of a typical checkweigher cycle see below

8.14.3. GA Get Triggered Average Value

[\[Index 0x2900 Sub 0x06\]](#)

This command reads the measurement result of a measurement cycle. The measurement value will averaged according the defined measuring time.

Master (PC / SPS) sends	Slave (DAD143.x) responds	Meaning
GA↵	A+001.100	Request: GA = 1100 g

Note: For preventing errors during the read out of the data the register GA has stored the value 99999 at the beginning of the measurement cycle. The measurement result can only be read after the defined measuring time MT has been elapsed and before a new measurement cycle has been started.

8.14.4. TE Trigger Edge

[\[Index 0x2500 Sub 0x02\]](#)

This command defines the trigger edge. Allowed settings are “0” for falling edge and “1” for rising edge. This command can only be used in conjunction with a hardware trigger on the digital input 0.

Master (PC / SPS) sends	Slave (DAD143.x) responds	Meaning
TE↵	E:001	Request: TE = 1 (rising edge)
TE 0↵	OK	Setup: TE = 0 (falling edge)

Default setting: TE = 0 [= falling edge]; time plot of a typical checkweigher cycle see below

8.14.5. TR Software Trigger

[Index 0x2005 Sub 0x03] or [... see chapter 13.2.7]

This command starts a measurement cycle. Its execution can be compared to a hardware trigger on the digital input channel 0.

Master (PC / SPS) sends	Slave (DAD143.x) responds	Meaning
TR↵	OK	Trigger event

8.14.6. TL Trigger Level

[Index 0x2500 Sub 0x01]

This command defines a level for a rising measurement signal, only. Setting range: 0 to 99999.

Master (PC / SPS) sends	Slave (DAD143.x) responds	Meaning
TL↵	T+99999	Request: TL = 99999
TL 1000↵	OK	Setup: TL = 1000

In the example a new measurement cycle would automatically start, if the signal exceeds 1000 d (e.g. 100.0 g; trigger commands SD and TL). Please read important note on next page.

Default setting: TL = 999999 [= trigger level disabled]

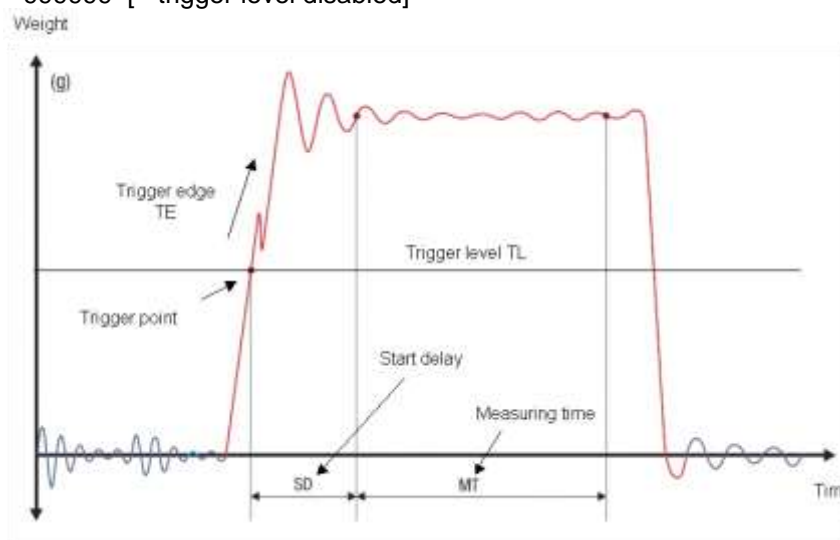

Figure: Time plot of a typical checkweigher weight signal while passing the scale.

Note: All trigger possibilities are always available in parallel. If a software trigger (command TR) or a hardware trigger (Digital input 0) will be used the trigger level should be set to its maximum value (TL = 999999). This setting disables the trigger level.

8.14.7. SA Send Triggered Average Value automatically

Master (PC / SPS) sends	Slave (DAD143.x) responds	Meaning
SA↵	OK	Auto-Transmit: triggered average value

This command will start to auto-transmit the measurement value of the current trigger cycle.

9. Legal For Trade Applications

The weighing indicators of the DAD 14x.y series have type approvals for Class III with 10000 parts according to OIML R76 for NSW (non-automatic weighing instruments) - DK xxxx.yyy revision n, according to the Directive 2014/31/EU. The minimum verification interval value is 0.2µV per increment.

With the type approval DK xxxx.yyy Revision n, a device of the DAD14x.y series can be used as a legal for trade weighing indicator for single-range and multi-interval scales. For further information please refer to the type approval (pending).

For the weighing indicators series DAD 14x.y an evaluation certificate for class III with 10000 parts for NSW (non-automatic weighing instruments) exists additional - DK 0199-17.01, in accordance with OIML R76:2006, EN45501:2015, WELMEC Guide 2.1:2001 and WELMEC Guide 8.8:2008. The minimum verification interval value is 0.2µV per increment.

With the evaluation certificate DK 0199-17.01 a device of the series DAD14x.y can be used for multi-range and multi-interval scales. For further information please refer to the evaluation certificate.

For legal for trade applications, the chosen certificate used must be marked on the housing, see section 5.1 on page 10.

9.1. Access to metrological data and weighing range adjustment

The access to the configuration and the adjustment function is made by means of a traceable code (TAC = Traceable Access Code), which is automatically increased as a non-volatile number by 1, each time the adjustment function is ended. The proof can be viewed by means of the command CE, which is answered with the status CExxxx. The code is limited up to max. 65535.

9.2. Protection of the metrological data and the scale calibration

Access to the configuration and adjustment function is protected by a code (TAC).

Setup or adjustments can only be made with the switch open (terminals 28). In case of changes, the value of the TAC counter is increased by 1 accordingly.

For legal-for-trade use, the two contacts must be jumpered and sealed. A damaged seal indicates an unauthorized modification of the adjustment.

10. Calibration and Calibration Sequence

The calibration of DAD143.x is only possible after starting a calibration sequence (compare with chapter 8.4).

- Command CE: Calibration enable – returns the current TAC value
- Command CM: Calibrate maximum display – sets the max. allowable display value
- Command CI: Calibrate minimum – sets the minimum allowable display value
- Command DS: Display step size – sets the output incremental step size
- Command DP: Decimal point – sets the position of the output decimal point
- Command CZ: Calibrate zero – sets the system zero point
- Command CG: Calibrate gain – sets the system gain
- Command ZT: Zero track enable / disable
- Command ZR: If applicable: Zero Range – sets the zero range manually
- Command ZI: If applicable: Initial Zero Range
- Command FD : If applicable: Reset to factory default settings
- Command CS : Save calibration data (TAC counter automatically incremented by 1)

Preparing the calibration:

- Check, if the max value of the display is set sufficiently high (see chapter 9.4.2, command CM)
- Check, if the no motion conditions are defined reasonable (chapter 9.5, e.g. NR = 1, NT = 1000)
- Set the IIR filter frequency to 0.5 Hz (see chapter 9.6, FM = 0, FL = 7)

Example: Setup of zero point, system gain and decimal point

The chosen calibration weight has the value 5000 (increments). That could be 500 g, 5 kg or 5000 kg. We calibrate with 500 g. The decimal point is set up by command DPx (x = 1, 2 or 3), here 1 figure after the decimal point. A measured weight of 500 g is displayed as 500.0.

Master (PC / SPS) sends	Slave (DAD143.x) responds	Meaning
CE↵	E+000017 (example)	Request: TAC counter CE17
Adjust zero: The scale has to be empty. No load!		
CE 17↵	OK	Calibration sequence active
CZ↵	OK	System zero point saved
Adjust gain: First put the calibration weight on the scale (here 500 g)!		
CE 17↵	OK	Calibration sequence active
CG 5000↵	OK	Setting span
CG↵	G+05000	Request: span 5000 d
CE 17↵	OK	Calibration sequence active
DP 1↵	OK	Setting: decimal point 0000.0
CE 17↵	OK	Calibration sequence active
CS↵	OK	Save calibration data in EEPROM

Zero point, gain and decimal point position were saved in the EEPROM; the calibration counter (TAC) is increase automatically by +1.

11. Firmware Update Program

For updating the firmware of the DAD143.x, a firmware package file **FWUPDATE.zip** must be transferred from a Windows based PC to an internal flash disk in the DAD 143.x through the service port, using the PC application program **PFL.exe**. When the firmware package is loaded into the DAD 143.x flash disk, it must be programmed into the DAD 143.x micro controller by the **FU** command.

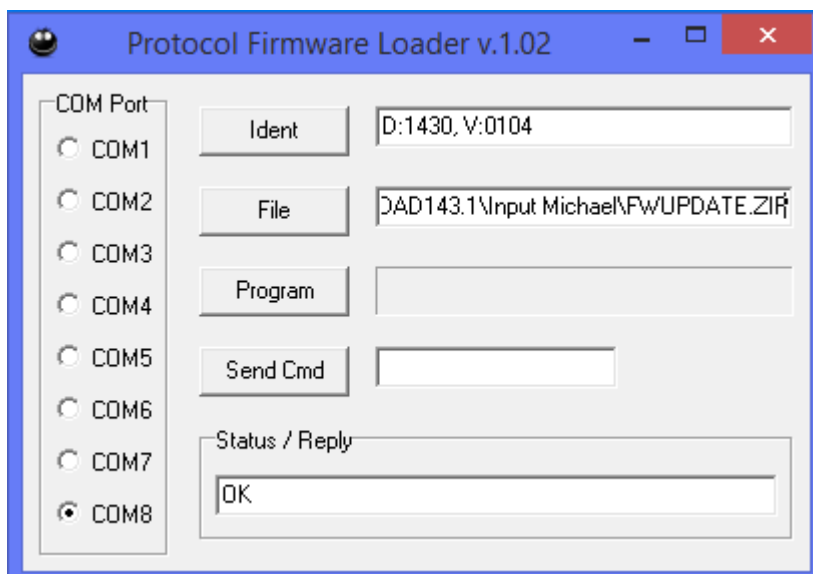

Screen shot of the PFL program

NOTE: The baud rate used by the **Protocol Firmware Loader** program is fixed to **115200 baud**.

The procedure for downloading the firmware package is as follows:

1. Run the program PFL.exe.
2. Connect the DAD143.x service port to one of the COM Ports COM1 to COM8 of a Windows PC. In this case 'COM8' is the COM port in use.
3. Press the **Ident** button. The Ident of the connected DAD143.x is 'D:1430, V:0104'.
4. Press the **File** button and choose in the right directory of the file 'FWUPDATE.zip'.
5. Press the **Program** button. Programming has several steps, which are:
 - Delete the 'old' programming. Finished with the message 'Done' in 'Status / Reply' field.
 - Programming starts with a blue progress bar in the field nearby (Win 10) and a 'blue rotating circle' covering the button showing process ongoing (Win 8.x), too.
 - Programming is finished when in field 'Status / Reply' the message 'Programing Done' appears.
6. Now use the button **Send Cmd** for the **FU** command to program the firmware into the micro controller.
7. After the DAD143.x re-starts with the LED tests and the display shows the new firmware version 01.04.
8. If you want to run the DAD143.x f.e. in Modbus TCP mode, you can use 'SendCmd' for setting **PS4** too, which means program select 4 (Modbus TCP). For another mode, choose PSx (see chapter 12).

11.1. FU Firmware Update

The FU command will transfer a new version of the main firmware from the internal flash disk to the flash memory in the DAD 143.x micro controller and re-start the device.

Download the actual PFL program from here: <https://www.haubac.com/haubac.asp?p1=267>

11.2. FD Reset to Factory Default Settings

This command puts the DAD143.x back to a known state. The data will be written to the EEPROM and the TAC will be incremented by +1.

Note: All calibration and setup information will be lost by issuing this command!

Master (PC / SPS) sends	Slave (DAD143.x) responds	Meaning
CE ¹⁷	E+00017 (example)	Request: TAC counter CE17
CE 17 ¹⁷	OK	Calibration sequence active
FD 0 ¹⁷	OK	Factory default setting

11.3. Import / Export of the Device Settings

Practicle Hint

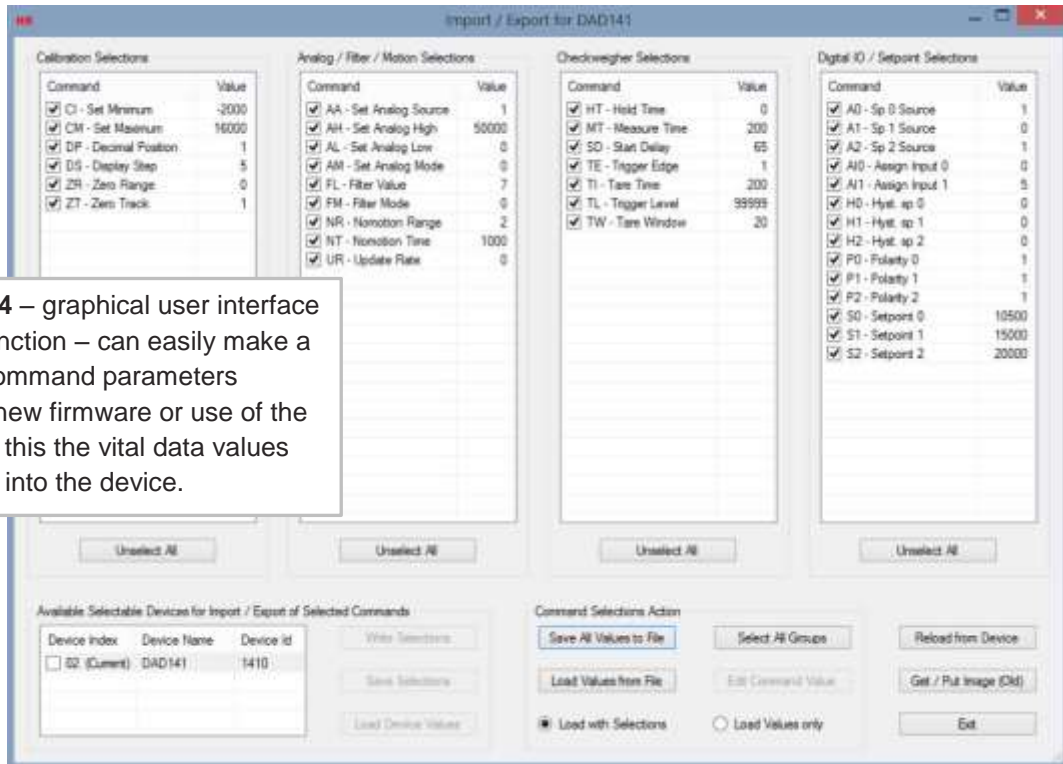

Download the actual DOP4 software for PC's with Windows OS (Win XP, Vista, 7, 8, 8.1 and 10) from here: <https://www.haubac.com/haubac.asp?p1=167>

www.haubac.com

Part 2 – Modbus TCP Commands

12. Service Commands – Overview Modbus TCP

Command	Short description	Parameter value
AP	Ethernet address assignment method	0..2
MA	Show one (of four) MAC address(es) assigned to the DAD 143.x	1..4
NA	Network Address (IP address)	aaa.bbb.ccc.ddd
NM	Network mask	aaa.bbb.ccc.ddd
NG	Default gateway address	aaa.bbb.ccc.ddd
PS	Protocol firmware select	1, 2, 3 or 4
SR	Software reset – restart the DAD143.x	None
WP	Write Parameters to non volatile memory	None

12.1. General System Commands – PS, SR and WP

12.1.1. PS Protocol Select

The DAD 143.x support a number of industrial Ethernet protocols. The respective protocol firmware type can be freely selected with the PS command.

PC sends	DAD 143.x responds	Meaning
PS↵	F:002 [Ethernet/IP]	Current protocol is Ethernet/IP
PS1↵	OK	Protocol firmware will be changed to type 1

After changing the protocol firmware, the DAD 143.x will save the setting and restart with the selected protocol activated. Available protocols:

Protocol type	Protocol name
1	Profinet IO
2	Ethernet/IP
3	EtherCAT
4	Modbus TCP

Factory default: PS=1.

Note: The PS setting can also be changed and saved from the front panel. Use front panel menu 8.8.

12.1.2. SR Software Reset

This command will respond with 'OK' and after 500 ms perform a complete reset of the DAD. It has the same functionality as power OFF and ON again.

PC sends	DAD 143.x responds	Meaning
SR↵	OK	The DAD will perform a software reset

12.1.3. WP Write Parameters

With this command the settings of the communication parameters can be saved in the nonvolatile memory.

PC sends	DAD 143.x responds	Meaning
WP↵	OK	The communication parameters are saved

12.2. Ethernet Setup Commands – NA, NM, NG, AP and MA

The Ethernet setup must be stored in nonvolatile memory with WP command and the DAD 143.x must be restarted eg. with the SR command before these settings take effect.

12.2.1. NA Network Address

When static IP address is selected the user must specify the IP address with the NA command.

PC sends	DAD 143.x responds	Meaning
NA↵	A:000.000.000.000	Current IP address is shown
NA 192.168.0.100↵	OK	IP address is set to 192.168.0.100

Factory default: 0.0.0.0

Note 1: Before using this command, static IP address must be selected (AP command).

This command has no effect if the DAD 143.x is in DCHP or BOOTP mode!

Note 2: The NA setting can also be changed and saved from the front panel. Use front panel menu 8.4.

12.2.2. NM Network Mask

When static IP address is selected the user must specify the network mask with the NM command.

PC sends	DAD 143.x responds	Meaning
NM↵	M:000.000.000.000	Current network mask is shown
NM 255.255.255.0↵	OK	Network mask is set to 255.255.255.0

Factory default: 0.0.0.0

Note 1: Before using this command, static IP address must be selected (AP command).

This command has no effect if the DAD 143.x is in DCHP or BOOTP mode!

Note 2: The NM setting can also be changed and saved from the front panel. Use front panel menu 8.5.

12.2.3. NG Network Gateway

When static IP address is selected the user must specify a default gateway address with the NG command.

PC sends	DAD 143.x responds	Meaning
NG↵	G:000.000.000.000	Current default gateway is shown
NG 192.168.0.254↵	OK	Default gateway is set to 192.168.0.254

Factory default: 0.0.0.0

Note 1: Before using this command, static IP address must be selected (AP command).

This command has no effect if the DAD 143.x is in DCHP or BOOTP mode!

Note 2: The NG setting can also be changed and saved from the front panel. Use front panel menu 8.6.

12.2.4. AP Address assign Protocol

The DAD 143.x can obtain its IP address in three different ways:

- A static IP address allocated by the user.
- A dynamic IP address allocated by a BOOTP server.
- A dynamic IP address allocated by a DHCP server.

The IP address allocation method can be selected with the AP command.

PC sends	DAD 143.x responds	Meaning
AP↵	P:002 [DHCP]	Current method is DHCP
AP 0↵	OK	Method is set to STATIC
AP 1↵	OK	Method is set to BOOTP
AP 2↵	OK	Method is set to DHCP

Factory default: DHCP

Note: The AP setting can also be changed and saved from the front panel. Use front panel menu 8.7.

12.2.5. MA MAC Addresses

The DAD 143.x is assigned four consecutive MAC addresses during manufacture. These MAC addresses cannot be changed by the user but they can be inspected using the MA command.

PC sends	DAD 143.x responds	Meaning
MA1←	00-02-A2-50-4A-47	Show MAC address 1
MA2←	00-02-A2-50-4A-48	Show MAC address 2
MA3←	00-02-A2-50-4A-49	Show MAC address 3
MA4←	00-02-A2-50-4A-4A	Show MAC address 4

13. Data Transfer - Modbus TCP

Measuring data and status information from the DAD can be read by the PLC as a complete data package. Commands can also be written as a data package from the PLC to the DAD.

13.1. Data read from the DAD 143.x by the PLC

13.1.1. Data package read from the DAD 143.x

The DAD 143.x hold a bank of registers (11) which can be read by the PLC. These registers shall be interpreted as follows:

Variable name	Data type	Register Index
CmdStatus	UINT32 ^{Note1}	40001
CmdRdData	INT32 ^{Note1}	40003
Data1	REAL32 ^{Note1}	40005
Data2	REAL32 ^{Note1}	40007
Qualifier	UINT16	40009
IoStatus	UINT16	40010
DataType2 / DataType1	UINT16	40011

Note1: MSB is in the first register.

13.1.2. CmdStatus

When a command is sent to the DAD through the data package exchange system this variable will hold a status information telling how the execution of the command went. The status codes are shown in the table below.

Bit 31	Bit 30	Bit 29	Bit 28	Bit 27	Bit 26	Bit 25	Bit 24	Bit 23	Bit 22	Bit 21	Bit 20	Bit 19	Bit 18	Bit 17	Bit 16
Not used 0	Not used 0	Not used 0	Not used 0	Not used 0	Not used 0	Not used 0	Not used 0	Not used 0	Not used 0	Not used 0	Not used 0	Not used 0	Not used 0	Not used 0	Not used 0

Bit 15	Bit 14	Bit 13	Bit 12	Bit 11	Bit 10	Bit 9	Bit 8	Bit 7	Bit 6	Bit 5	Bit 4	Bit 3	Bit 2	Bit 1	Bit 0
Not used 0	Not used 0	Not used 0	Not used 0	Not used 0	Not used 0	Not used 0	Not used 0	ACK	Not used 0	Not used 0	Not used 0	Status bit 3	Status bit 2	Status bit 1	Status bit 0

Bit 7 is an acknowledge bit and it will toggle everytime the status information is updated.

The lower four bits (0 to 3) contain the status code:

Status code	Bit 3	Bit 2	Bit 1	Bit 0	Meaning
0	0	0	0	0	No error - OK
1	0	0	0	1	Index does not exist
2	0	0	1	0	Subindex does not exist
3	0	0	1	1	The given parameter is out of range
4	0	1	0	0	Calibration lock not open
5	0	1	0	1	The command is not allowed
6	0	1	1	0	Attempt to read a write-only parameter
7	0	1	1	1	Attempt to write a read-only parameter
8	1	0	0	0	-
9	1	0	0	1	Command failed
10	1	0	1	0	Zeroing disabled
11	1	0	1	1	Out of zero range

12	1	1	0	0	Input range exceeded
13	1	1	0	1	Load cell connection error
14	1	1	1	0	Reading not stable
15	1	1	1	1	Out of tare range

13.1.3. CmdRdData

When a read command is sent to the DAD through the data package exchange system this variable will hold the data read from the DAD.

13.1.4. Data1

This variable holds a data value specified by the programmer. See 8.2.8 Select1

13.1.5. Data2

This variable holds a data value specified by the programmer. See 8.2.9 Select2

13.1.6. Qualifier

This variable holds an extended status word. The Qualifier for the DAD 143.x is defined as:

Bit 15	Bit 14	Bit 13	Bit 12	Bit 11	Bit 10	Bit 9	Bit 8	Bit 7	Bit 6	Bit 5	Bit 4	Bit 3	Bit 2	Bit 1	Bit 0
Not used 0	Average data ready	Filling completed	Filling in progress	Not used 0	Not used 0	Range bit 1	Range bit 0	ADC Error	Preset tare set	Tare set	No motion	Center zero	Not within zero range	Over range	Under range

The range bits are defined as:

Range bit 1	Range bit 0	Meaning
0	0	The scale is operating as a single range / interval scale
0	1	The scale is in range / interval 1
1	0	The scale is in range / interval 2
1	1	The scale is in range / interval 3

13.1.7. IO Status

This variable holds the status of the logic in- and outputs.

Bit 15	Bit 14	Bit 13	Bit 12	Bit 11	Bit 10	Bit 9	Bit 8	Bit 7	Bit 6	Bit 5	Bit 4	Bit 3	Bit 2	Bit 1	Bit 0
Not used 0	Not used 0	Not used 0	Not used 0	Not used 0	Not used 0	Not used 0	Not used 0	Not used 0	Output 2 Active	Output 1 Active	Output 0 Active	Not used 0	Not used 0	Input 1 Active	Input 0 Active

13.1.8. Data Type1

This variable indicates which kind of data Data1 holds. The DataType1 parameter is contained in the lower 8 bits of register 40011. See 13.2.8 Select1.

13.1.9. Data Type2

This variable indicates which kind of data Data2 holds. The DataType2 parameter is contained in the upper 8 bits of register 40011. See 13.2.9 Select2.

13.2. Data written from the PLC to the DAD 143.x

13.2.1. Data package written to the DAD 143.x

The PLC can write into a bank of registers (6) inside the DAD 143.x. These registers shall be interpreted as follows:

Variable name	Data type	Register Index
CmdWrData	INT32 ^{Note1}	40501
Index	UINT16	40503
RW	SubIndex	40504
ShortCmd	SendCmd	40505
Select2	Select1	40506

Note1: MSB is in the first register.

13.2.2. CmdWrData

When data has to be written to the DAD then the data must be placed in this variable.

13.2.3. Index

A variable or parameter in the DAD 143.x is addressed by an index and a subindex. Appendix A contain a list of available indexes and subindexes in the DAD 143.x.

13.2.4. Subindex

A variable or parameter in the DAD 143.x is addressed by an index and a subindex. Appendix A contain a list of available indexes and subindexes in the DAD 143.x. The subindex is contained in the lower 8 bits of register 40504.

13.2.5. RW

This parameter selects between read and write commands. The RW parameter is contained in the upper 8 bits of register 40504.

RW	Meaning
0	A write command will be sent
1	A read command will be sent

13.2.6. SendCmd

This parameter is used for triggering the sending of a command. When its value changes from 0 to 1 the command will be sent. The send command parameter is contained in the lower 8 bits of register 40505.

SendCmd	Action
0	Nothing happens
0→1	The command will be sent
1→0	Nothing happens
1	Nothing happens

13.2.7. ShortCmd

This parameter is a bit mapped value there can be used for sending basic commands to the DAD. The following bit mapped commands are defined for the DAD 143.x. The short command parameter is contained in the upper 8 bits of register 40505.

Bit 7	Bit 6	Bit 5	Bit 4	Bit 3	Bit 2	Bit 1	Bit 0
Not used	Hold	Clear max	Trigger	Set Tare	Reset Tare	Set Zero	Reset Zero

Note 1: The bits should only be set one at a time.

13.2.8. Select1

This parameter controls which data goes into Data1 in the data package read by the PLC. The select1 parameter is contained in the lower 8 bits of register 40506. The defined values are:

Select1	Data1
0	Gross weight
1	Net weight
2	Tare weight
3	Average weight
4	Dosed weight
5	Peak value
6	Hold value
7	Valley value
8	Peak to peak value
9 to 255	Undefined, set to zero

13.2.9. Select2

This parameter has the same coding as Select1 but controls which data goes into Data2 in the data package read by the PLC. The select2 parameter is contained in the upper 8 bits of register 40506.

14. Appendix A – Command list ‘MODBUS TCP’ for the DAD 143.x

Index	Sub-Index	Name	Type	Attribut	Default Value	Meaning
0x2000	0x00	Number of entries.	UI8	ro	0x06	Number of entries.
	0x01	Gross weight.	REAL32	ro	-	Get gross weight – GG command.
	0x02	Net weight.	REAL32	ro	-	Get net weight – GN command.
	0x03	Tare.	REAL32	ro	-	Get tare weight – GT command.
	0x04	Dosed weight.	REAL32	ro	-	Get dosed weight – GD command (<i>FT1 or FT3</i>).
	0x05	Dosed tare.	REAL32	ro	-	Get dosed tare weight – DT command (<i>FT1 or FT3</i>).
	0x06	Average weight.	REAL32	ro	-	Get average weight – GA command.
0x2001	0x00	Number of entries.	I32	ro	0x06	Number of entries.
	0x01	Gross weight.	I32	ro	-	Get gross weight – GG command.
	0x02	Net weight.	I32	ro	-	Get net weight – GN command.
	0x03	Tare.	I32	ro	-	Get tare weight – GT command.
	0x04	Dosed weight.	I32	ro	-	Get dosed weight – GD command (<i>FT1 or FT3</i>).
	0x05	Dosed tare.	I32	ro	-	Get dosed tare weight – DT command (<i>FT1 or FT3</i>).
	0x06	Average weight.	I32	ro	-	Get average weight – GA command.
0x2004	0x00	Number of entries.	UI8	ro	0x05	Number of parameters.
	0x01	Save Analog.	UI8	wo	-	Save analog output settings – AS command
	0x02	Save Calibration.	UI8	wo	-	Save calibration settings (TAC protected) – CS command.
	0x03	Save General set-up.	UI8	wo	-	Save general set-up parameters – WP command.
	0x04	Save Dosed.	UI8	wo	-	Save dosing setup parameters command – SD command.
	0x05	Save Set-points.	UI8	wo	-	Save set-point parameters – SS command.
0x2005	0x00	Number of entries.	UI8	ro	0x03	Number of entries.
	0x01	Start command.	UI8	wo	-	Start Cycle – SC command (<i>FT1 or FT3</i>).
	0x02	Stop command.	UI8	wo	-	Abort Cycle – AC command (<i>FT1 or FT3</i>).
	0x03	Trigger command.	UI8	wo	-	Trigger – TR command.
0x2006	0x00	Number of entries.	UI8	ro	0x03	Number of entries.
	0x01	Not used.	UI8	wo	-	Not used.
	0x02	Factory Default.	UI8	wo	-	Set factory default values (TAC protected) – FD command.
	0x03	Command byte.	UI8	wo	-	See [Cyclic data] – ShortCmd, see chapter 13.2.7.

Index	Sub-Index	Name	Type	Attribut	Default Value	Meaning
0x2007	0x00	Number of entries.	UI8	ro	0x04	Number of entries.
	0x01	Not used.	UI8	rw	0	Not used.
	0x02	Not used.	UI8	rw	0	Not used.
	0x03	Not used.	UI8	rw	0	Not used.
	0x04	Software reset.	UI8	wo	-	Software reset – SR command.
0x2100	0x00	Number of entries.	UI8	ro	0x19	Number of parameters.
	0x01	Analog action.	UI32	rw	0	Analog action – AA command.
	0x02	Analog high.	UI32	rw	0	Analog high value – AH command.
	0x03	Analog low.	UI32	rw	0	Analog low value – AL command.
	0x04	Filter setting.	UI8	rw	3	Filter setting –FL command.
	0x05	Not used.	UI32	rw	0	Not used.
	0x06	Logic outputs.	UI8	rw	-	Digital Outputs – IO command.
	0x07	Logic inputs.	UI8	ro	-	Digital Inputs – IN command
	0x08	Measure Time.	UI16	rw	0	Measuring Time – MT command.
	0x09	Filter Mode.	UI8	rw	0	Filter mode – FM command.
	0x0A	No motion Range.	UI16	rw	1	No-motion range – NR command.
	0x0B	No motion Time.	UI16	rw	1000	No-motion time – NT command.
	0x0C	Output Mask.	UI8	rw	0	Digital outputs mask – OM command.
	0x0D	Not used.	U32	rw	0	Not used.
	0x0E	Start Delay.	UI16	rw	0	Start Delay – SD command.
	0x0F	Not used.	UI32	rw	0	Not used.
	0x10	Not used.	UI32	rw	0	Not used.
	0x11	Update Rate.	UI8	rw	0	Update rate –UR command.
	0x12	Zero Tracking.	UI8	rw	0	Zero track (TAC protected) – ZT command.
	0x13	Not used.	UI32	rw	0	Not used.
0x14	Not used.	UI32	rw	0	Not used.	
0x15	Analog mode.	UI32	rw	0	Analog mode – AM command.	
0x16	Pre-filter	UI8	rw	1	Pre-filter – PF command.	
0x17	Preset Tare	I32	rw	0	Preset Tare – SP command.	
0x18	Not used.	UI32	rw	0	Not used.	
0x19	Analog reference	I32	rw	0	Analog Reference value – AR command.	

Index	Sub-Index	Name	Type	Attribut	Default Value	Meaning
0x2200 Only for use with FW type 1	0x00	Number of entries.	UI8	ro	0x17	Number of parameters
	0x01	Pre-fill mode.	I32	rw	0	PreFill Mode – PD1 command.
	0x02	In-flight correction factor.	I32	rw	0	Inflight Correction – PD2 command.
	0x03	Zero check time.	I32	rw	0	Zero Check time – PD3 command.
	0x04	Tare delay.	I32	rw	0	Tare Delay – PD4 command.
	0x05	Tare average time.	I32	rw	0	Tare Average Time – PD5 command.
	0x06	Delay after prefill.	I32	rw	0	Delay After Prefill – PD6 command.
	0x07	Blanking time.	I32	rw	0	Blanking Time – PD7 command.
	0x08	In-flight delay time.	I32	rw	0	Inflight Delay Time – PD8 command.
	0x09	Dosed weight average time.	I32	rw	0	Fill Weight Average Time – PD9 command.
	0x0A	Zero tolerance.	I32	rw	0	Zero Tolerance – PD10 command.
	0x0B	Tare reference.	I32	rw	0	Tare Reference – PD11 command.
	0x0C	Tare tolerance.	I32	rw	0	Tare Tolerance – PD12 command.
	0x0D	Pre-fill level for 1 st prefill.	I32	rw	0	Prefill Level 1 – PD13 command.
	0x0E	Fine fill weight.	I32	rw	0	Fine Fill Weight – PD14 command.
	0x0F	Filling weight.	I32	rw	0	Filling Weight – PD15 command.
	0x10	In-flight value.	I32	rw	0	Inflight Value – PD16 command.
	0x11	Pre fill level for 2 nd prefill.	I32	rw	0	Prefill Level 2 – PD17 command.
	0x12	Timeout value for filling cycle	I32	rw	0	Fill Timeout Value – PD18 command.
	0x13	Underweight post fill time.	I32	rw	0	Underweight Post Fill Time – PD19 command.
	0x14	Tare interval.	I32	rw	1	Tare Interval – PD20 command.
	0x15	Bag Rupture blanking.	I32	rw	0	Bag Rupture Blanking – PD21 command.
	0x16	Medium fill weight.	I32	rw	0	Medium Fill Weight – PD22 command.
0x17	Production counter.	I32	rw	0	Production Counter – PD23 command.	

Index	Sub-Index	Name	Type	Attri-but	Default Value	Meaning
0x2200 Only for use with FW type 3	0x00	Number of entries.	UI8	ro	0x17	Number of parameters
	0x01	Pre-fill mode.	I32	rw	0	PreFill Mode – PD1 command.
	0x02	In-flight correction factor.	I32	rw	0	Inflight Correction – PD2 command.
	0x03	Not used.	I32	rw	0	Not used in FW type 3
	0x04	Delay time after re-filling	I32	rw	0	Delay time after re-filling hopper – PD4.
	0x05	Not used.	I32	rw	0	Not used in FW type 3.
	0x06	Delay after prefill.	I32	rw	0	Delay After Prefill – PD6 command.
	0x07	Blanking time.	I32	rw	0	Blanking Time – PD7 command.
	0x08	In-flight delay time.	I32	rw	0	Inflight Delay Time – PD8 command.
	0x09	Dosed weight average time.	I32	rw	0	Fill Weight Average Time – PD9 command.
	0x0A	Hopper weight – lower level.	I32	rw	0	Lower threshold for hopper re-filling – PD10.
	0x0B	Hopper weight – upper level.	I32	rw	0	Upper threshold for hopper re-filling – PD11.
	0x0C	Re-weighing threshold.	I32	rw	0	Threshold for hopper re-weighing – PD12.
	0x0D	Pre-fill level for 1 st prefill.	I32	rw	0	Prefill Level 1 – PD13 command.
	0x0E	Fine fill weight.	I32	rw	0	Fine Fill Weight – PD14 command.
	0x0F	Filling weight.	I32	rw	0	Filling Weight – PD15 command.
	0x10	In-flight value.	I32	rw	0	Inflight Value – PD16 command.
	0x11	Pre fill level for 2 nd prefill.	I32	rw	0	Prefill Level 2 – PD17 command.
	0x12	Timeout value for filling cycle	I32	rw	0	Fill Timeout Value – PD18 command.
	0x13	Not used.	I32	rw	0	Not used in FW type 3.
0x14	Not used.	I32	rw	1	Not used in FW type 3.	
0x15	Not used.	I32	rw	0	Not used in FW type 3.	
0x16	Not used.	I32	rw	0	Not used in FW type 3.	
0x17	Production counter.	I32	rw	0	Production Counter – PD23 command.	

Index	Sub-Index	Name	Type	Attribut	Default Value	Meaning
0x2300	0x00	Number of entries.	UI8	ro	0x19	Number of calibration parameters.
	0x01	Absolute gain.	I32	rw	10000	Absolute gain calibrate (TAC protected) – AG command.
	0x02	Absolute zero.	I32	rw	0	Absolute zero calibrate (TAC protected) – AZ command.
	0x03	Calibrate enable.	I32	rw	-	Calibrate enable (enables TAC when the TAC is written) – CE command.
	0x04	Calibrate gain.	I32	rw	10000	Calibrate gain (TAC protected) – CG command.
	0x05	Not used.	I32	rw	0	Not used.
	0x06	Not used.	I32	rw	0	Not used.
	0x07	Define max 1.	I32	rw	10009	Calibrate max 1 (TAC protected) – CM1 command.
	0x08	Define min.	I32	rw	-10009	Calibrate min (TAC protected) – CI command.
	0x09	Not used.	I32	rw	0	Not used.
	0x0A	Calibrate zero.	I32	rw	0	Calibrate zero (TAC protected) – CZ command.
	0x0B	Decimal point.	I32	rw	0	Decimal point (TAC protected) – DP command.
	0x0C	Display step size.	I32	rw	1	Display step size (TAC protected) – DS command.
	0x0D	Multi Range.	I32	rw	0	Multi range / multi interval selection (TAC protected) – MR command.
	0x0E	Define max 2.	I32	rw	0	Calibrate max 2 (TAC protected) – CM2 command.
	0x0F	Define max 3.	I32	rw	0	Calibrate max 3 (TAC protected) – CM3 command.
	0x10	Initial zero range.	I32	rw	0	Initial zero range (TAC protected) – ZI command.
	0x11	Zero Range.	I32	rw	0	Zero range (TAC protected) – ZR command.
	0x12	Tare mode.	I32	rw	0	Tare mode (TAC protected) – TM command.
	0x13	Non volatile tare.	I32	rw	0	Non volatile / volatile tare select (TAC protected) – TN command.
0x14	Non volatile zero.	I32	rw	0	Non volatile / volatile zero select (TAC protected) – ZN command.	
0x15	Firmware type.	I32	rw	0	Firmware type (TAC protected) – FT command.	
0x16	Not used.	I32	rw	0	Not used.	
0x17	Not used.	I32	rw	0	Not used.	
0x18	Calibration value.	I32	rw	0	Number of increments for absolute calibration (TAC protected) – CV cmd.	
0x19	Auto zero mode.	I32	rw	0	Auto zero mode (TAC protected) – ZM command	
0x2400	0x00	Number of entries.	UI8	ro	0x01	Number of entries.
	0x01	Get Dose Info	I32	ro		Dose Status Info – DI command (<i>FT1 or FT3</i>).
0x2500	0x00	Number of entries.	UI8	ro	0x07	Number of Check-Weigher parameters.
	0x01	Trigger Level.	I32	rw	999999	Trigger Level – TL command.
	0x02	Trigger Egde.	I32	rw	0	Trigger Egde – TE command.
	0x03	Not used.	I32	rw	0	Not used.
	0x04	Not used.	I32	rw	0	Not used.
	0x05	HoldTime.	I32	rw	0	HoldTime – HT command.
	0x06	TareWindow.	I32	rw	0	TareWindow – TW command.
	0x07	TareTime.	I32	rw	0	TareTime – TI command.

Index	Sub-Index	Name	Type	Attribut	Default Value	Meaning
0x2600	0x00	Number of entries.	UI8	ro	0x03	Number of Set-points
	0x01	Set-point 1 value.	I32	rw	1000	Set-point 1 value – S0 command.
	0x02	Set-point 2 value.	I32	rw	5000	Set-point 2 value – S1 command.
	0x03	Set-point 3 value.	I32	rw	9999	Set-point 3 value – S2 command.
0x2680	0x00	Number of entries.	UI8	ro	0x03	Number of Set-point parameters.
	0x01	Polarity set-point 1.	UI8	rw	1	Set-point 1 polarity – P0 command.
	0x02	Polarity set-point 2.	UI8	rw	1	Set-point 2 polarity – P1 command.
	0x03	Polarity set-point 3.	UI8	rw	1	Set-point 3 polarity – P2 command.
0x2700	0x00	Number of entries.	UI8	ro	0x03	Number of Set-point parameters.
	0x01	Hysteresis set-point 1.	I32	rw	0	Set-point 1 hysteresis – H0 command.
	0x02	Hysteresis set-point 2.	I32	rw	0	Set-point 2 hysteresis – H1 command.
	0x03	Hysteresis set-point 3.	I32	rw	0	Set-point 3 hysteresis – H2 command.
0x2800	0x00	Number of entries.	UI8	ro	0x03	Number of Set-point parameters.
	0x01	Alloc. source set-point 1.	UI8	rw	1	Set-point 1 allocation source – A0 command.
	0x02	Alloc. source set-point 2.	UI8	rw	1	Set-point 2 allocation source – A1 command.
	0x03	Alloc. source set-point 3.	UI8	rw	1	Set-point 3 allocation source – A2 command.
0x2900	0x00	Number of entries.	UI8	ro	0x12	Number of entries in info array.
	0x01	Gross weight.	REAL32	ro	-	Get gross weight – GG command.
	0x02	Net Weight.	REAL32	ro	-	Get net weight – GN command.
	0x03	Tare.	REAL32	ro	-	Get tare weight – GT command.
	0x04	Dosed Weight.	REAL32	ro	-	Get dosed weight – GD command (<i>FT1 or FT3</i>).
	0x05	Dosed Tare.	REAL32	ro	-	Get dosed tare weight – DT command (<i>FT1 or FT3</i>).
	0x06	Average weight.	REAL32	ro	-	Get average weight – GA command.
	0x07	A/D sample.	I32	ro	-	Get A/D sample value – GS command.
	0x08	Device ID.	UI32	ro	0x3014	Get ID – ID command.
	0x09	FW Version.	UI32	ro	-	Get firmware version – IV command.
	0x0A	Device Status.	UI32	ro	-	Get status – IS command.
	0x0B	Not used.	UI32	ro	0	Not used.
	0x0C	Serial Number.	UI32	ro	-	Get serial number – RS command.
	0x0D	Qualifier.	UI32	ro	-	Get qualifier. See cyclic data - Qualifier
0x0E	Get peak value.	REAL32	ro	-	Get peak value – GM command.	
0x0F	Get hold value.	REAL32	ro	-	Get hold value – GH command.	
0x10	Get valley value.	REAL32	ro	-	Get valley value – GV command.	
0x11	Get peak to peak value.	REAL32	ro	-	Get peak to peak value – GO command.	
0x12	Show internal mV/V.	I32	ro	-	Show internal mV/V value – AV command.	

Index	Sub-Index	Name	Type	Attribut	Default Value	Meaning
0x2D00	0x00	Number of entries.	UI8	ro	0x02	Number of entries in assign input parameters.
	0x01	Assign input 0.	UI8	rw	0	Assign input 0 – AI 0 command.
	0x02	Assign input 1.	UI8	rw	0	Assign input 1 – AI 1 command.

15. Appendix B - Change network settings AP, NA, NM and NG with Modbus TCP Viewer

How to change the network settings of the cmds AP, NA, NM and NG:

1. Connect the DAD143.x via serial port RS232 with your PC, e.g. with a converter cable from RS232 to USB.
2. Start the program Modbus TCP Viewer on your PC. If necessary, check first the baud rate. The required setting is 115200 baud.
3. Below you see the main window of the Modbus TCP Viewer ver. 1.0.0.0. The Modbus TCP communication is active. Press the button 'Service Commands' for the next window.

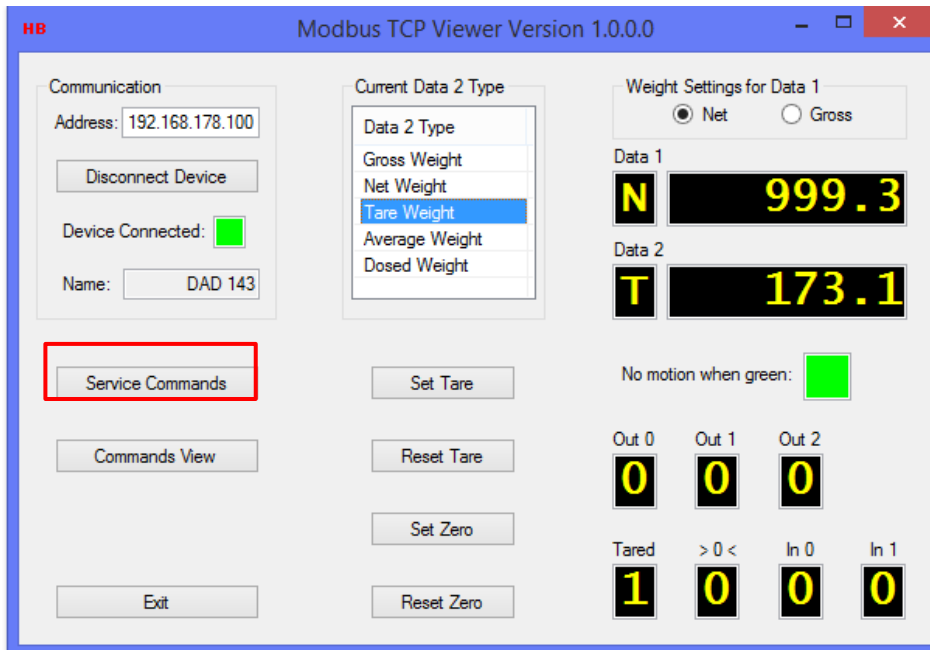

4. The window below shows next button to use - Connect Service Port

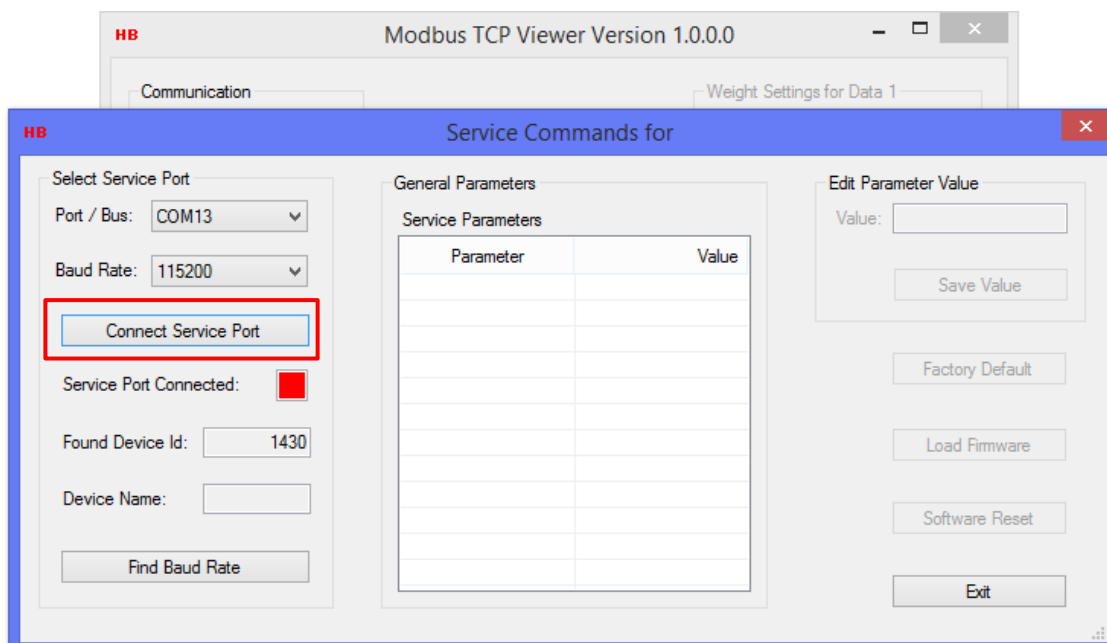

5. The Service Parameters window shows the network parameters, which you can change if necessary / wanted, see below.

Note: After setting the cmd PS (protocol select) to 4 (Modbus TCP), the Network Address, Gateway and Mask are set to 0.0.0.0 (it's factory default). For using Modbus TCP, the Address Method DHCP (factory default) must be changed to STATIC.

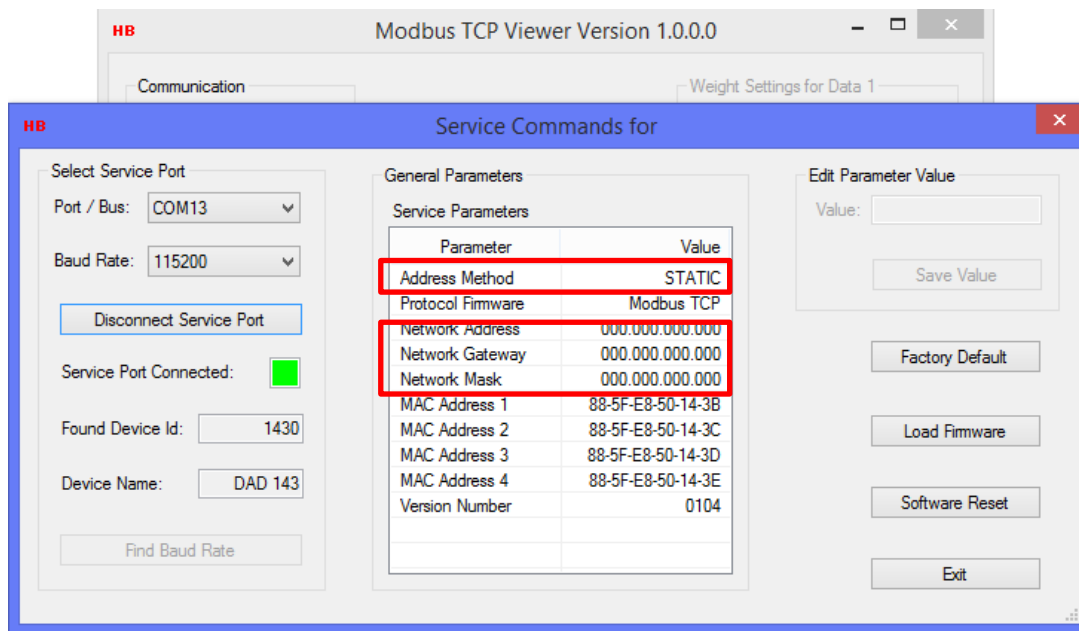

6. Below you see in the window the setup of a new Network Address:

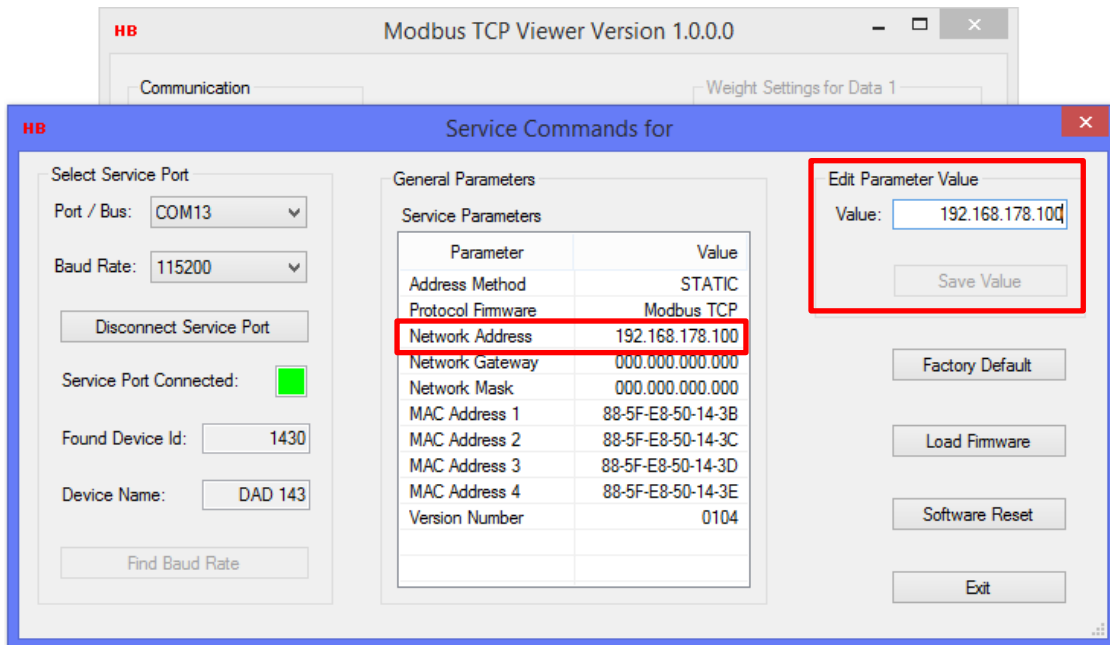

7. Below you see in the window the setup of the new Network Mask:

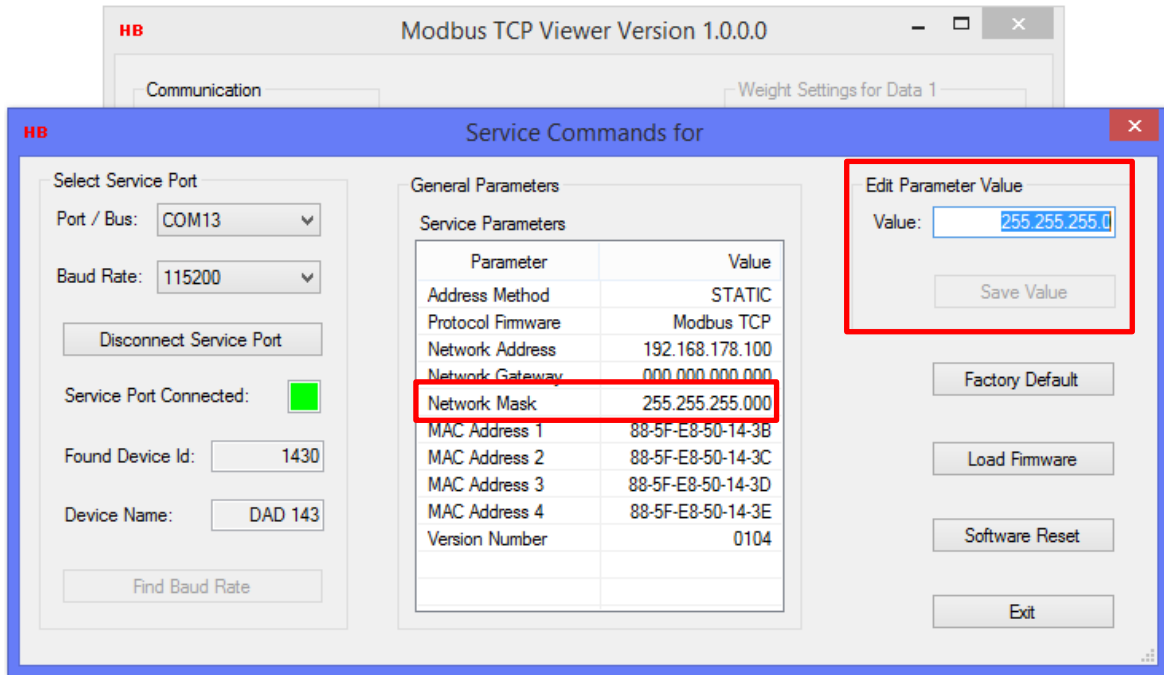

8. Below you see in the window the setup of the new Network Gateway:

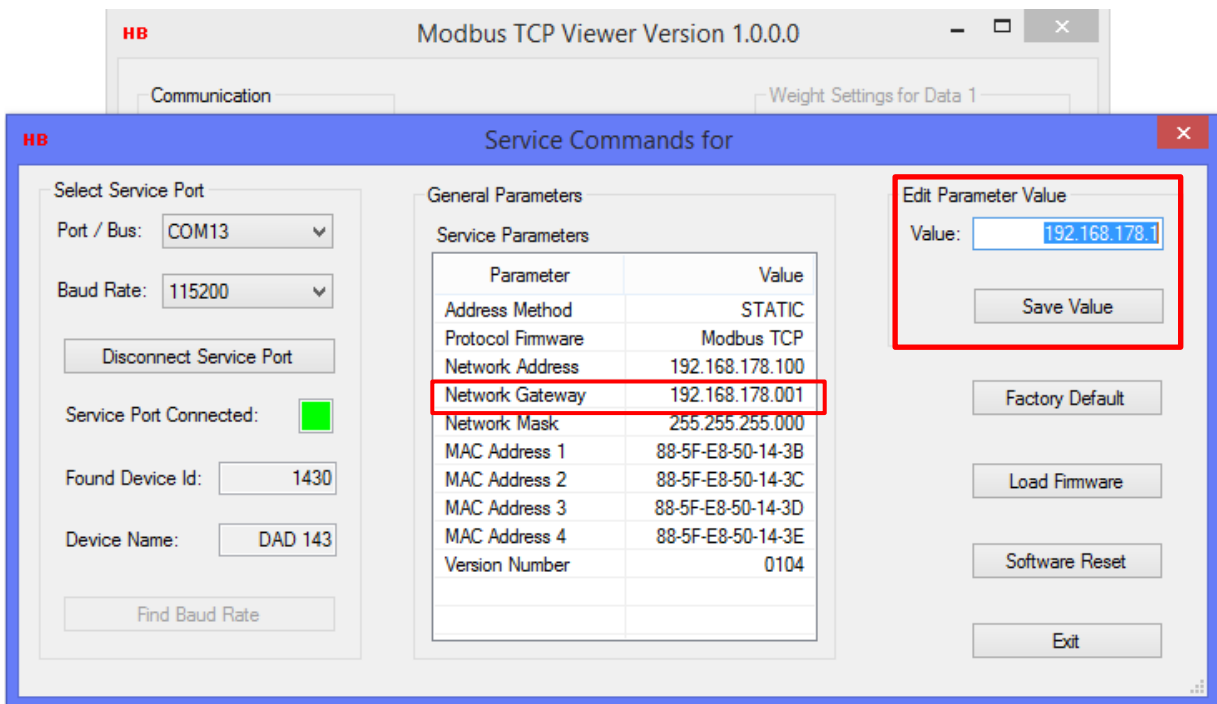

9. After 'Network Address' settings are finished, leave this window via button 'Disconnect Service Port':

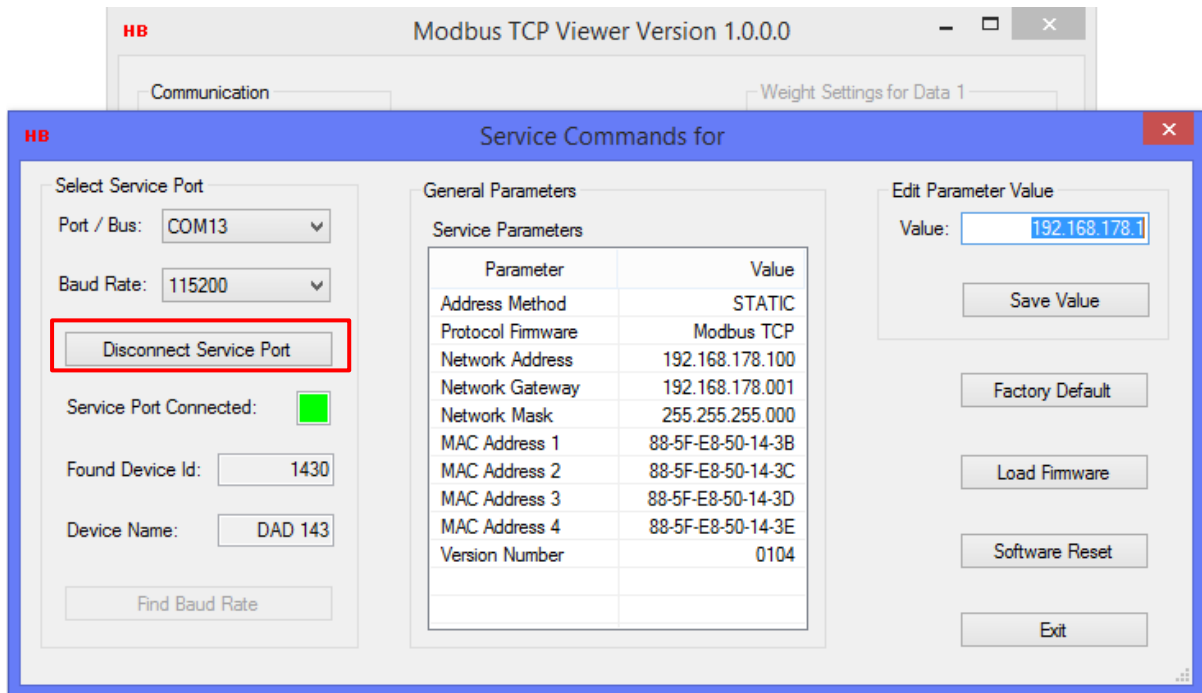

10. ... and Exit this window:

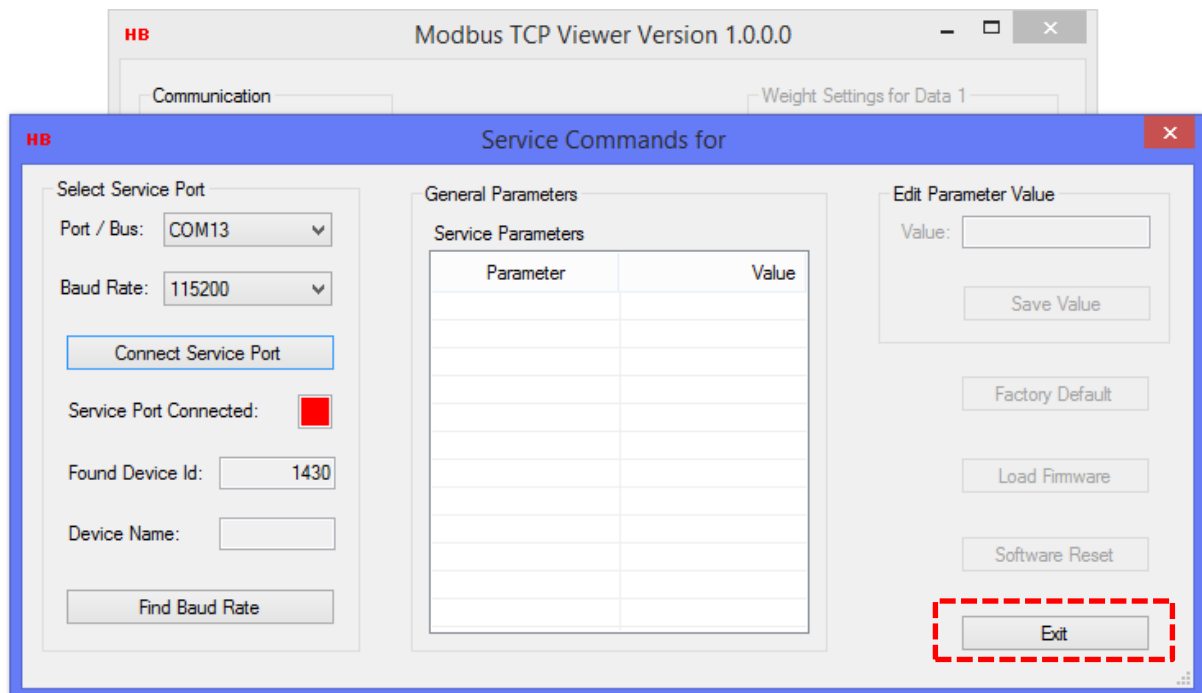

11. Disconnect the DAD143.x from service port and connect Modbus TCP via Port 1 / 2:

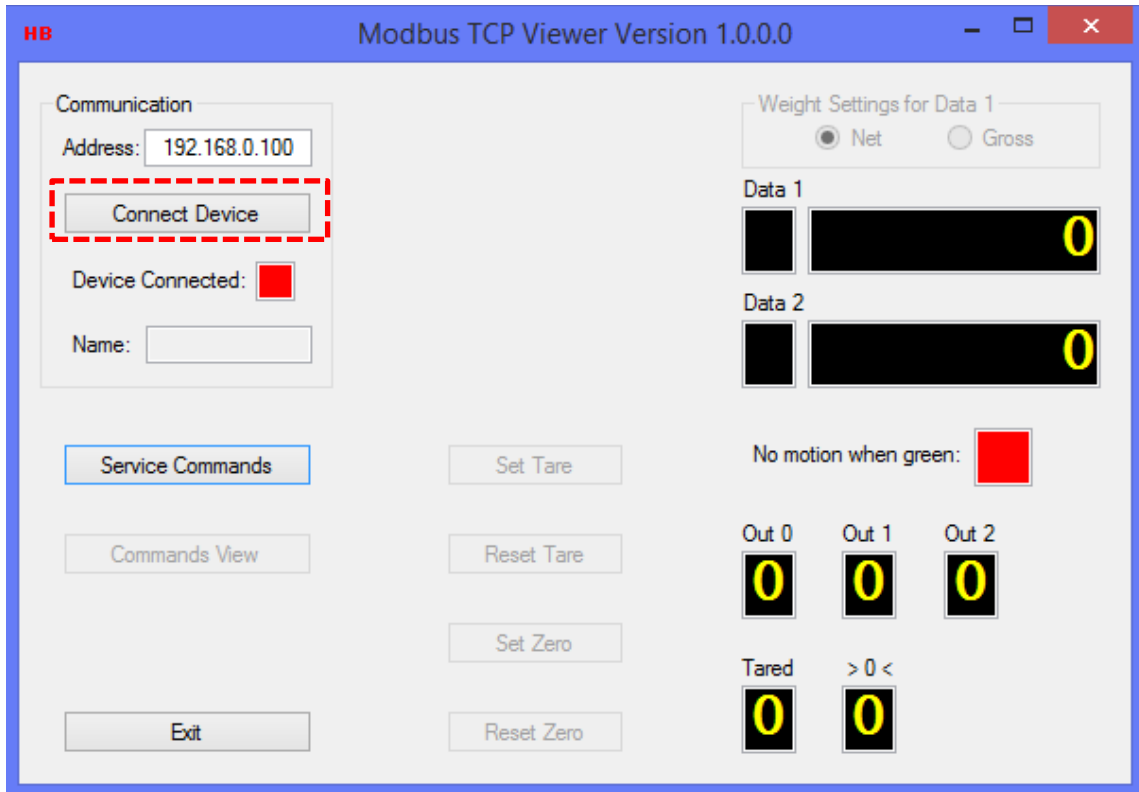

Notes:

- Edit the Communication Address to your settings you did via Service Commands or front panel menu
- in our case the setting was 192.168.178.100
- and press the button Connect Device.

12. The DAD143 has now Communication to the PC via Modbus TCP:

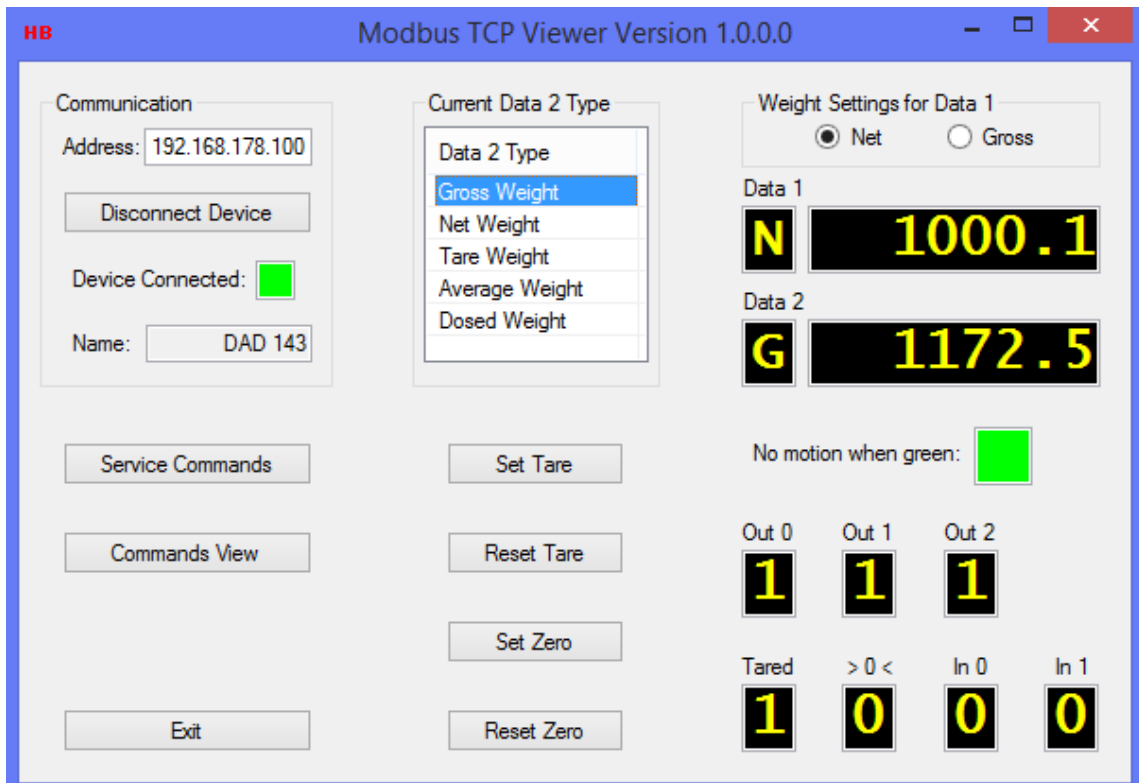

13. Use the button 'Commands View' for detailed informations of the different commands:

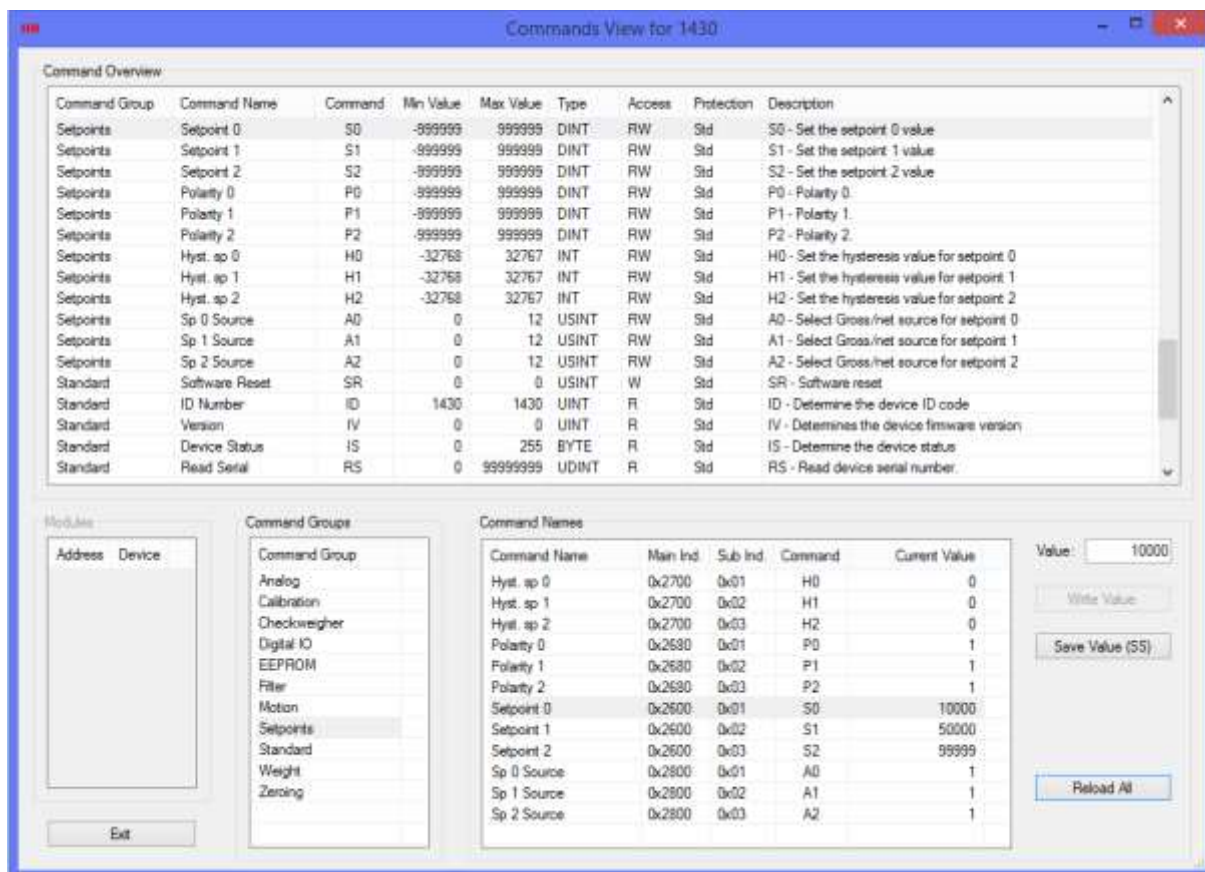

In Commands View/Names window you see the Indexes and Sub-Indexes for Modbus TCP protocol.

- Mark one cmd, e.g. 'Setpoint 0', edit a new value for the S0 cmd.
- For storing, press buttons 'Write value' and after 'Save Value (SS)'.
- With Exit you leave this Command Overview window.

14. Use the button 'Commands View' for detailed informations of the different commands:

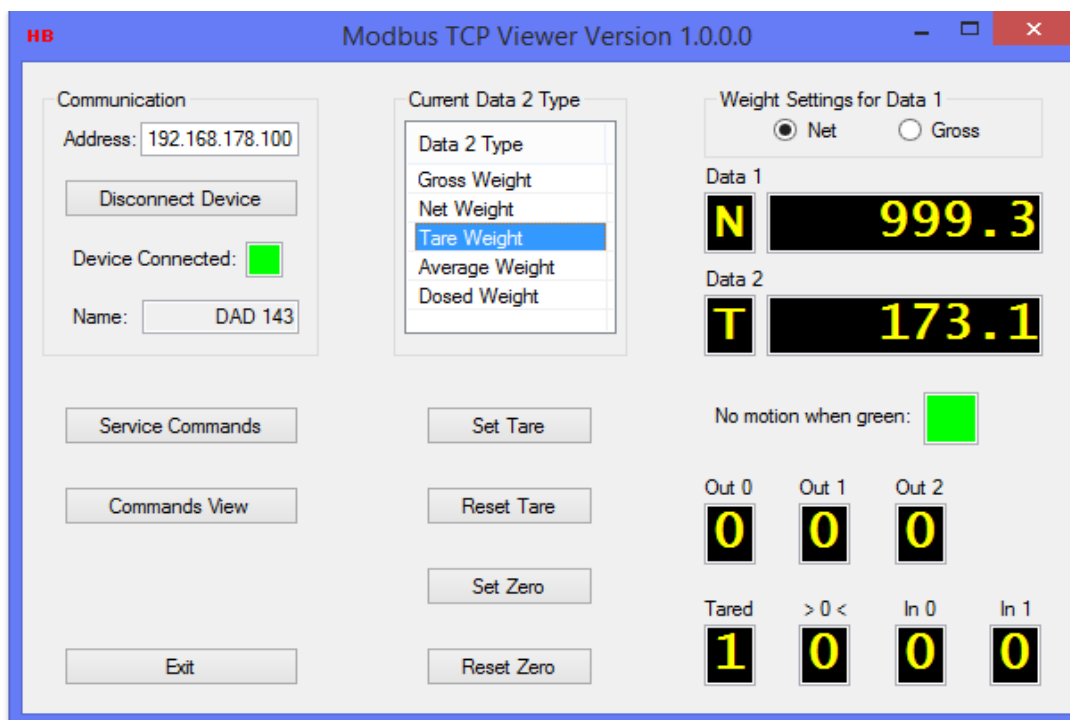

1. Weight settings DATA1 you can choose as Net or Gross, shown in the upper display, and for DATA 2 you can choose the weights Gross or Net or Tare or Average or Dosed. Data2 is shown in the lower display.
2. Data1 shows the Net Weight and Data2 the Tare Weight.
3. The buttons Set / Reset Tare and Set / Reset Zero can be used for taring and zeroing. But only when the 'no motion' LED is green !

Hauch & Bach ApS
Femstykket 6
DK-3540 Lynge
Denmark
www.haubac.com